

1. Evaluate.

$$(-9)^1$$
$$\boxed{-9}$$

2. Evaluate.

$$-(8)^1$$
$$\boxed{-8}$$

3. Evaluate.

$$-1^3$$
$$\boxed{-1}$$

4. Evaluate 6^{-2} . Express your answer as a whole number or a fraction in simplest terms.

$$\boxed{\frac{1}{36}}$$

5. Evaluate 7^{-1} . Express your answer as a whole number or a fraction in simplest terms.

$$\boxed{\frac{1}{7}}$$

6. Evaluate 10^0 . Express your answer as a whole number or a fraction in simplest terms.

$$\boxed{1}$$

7. Which expression is equivalent to $6^4 \times 6^{-4}$?

- A. 0 B. 6^{-8} $\boxed{C. 1}$ D. 6^8

8. Which expression is equivalent to $\frac{4}{4^3}$?

- A. 4^2 B. $\frac{1}{4^3}$ $\boxed{C. \frac{1}{4^2}}$ D. 4^4

9. Which expression is equivalent to $(6^{-1})^{-2}$?

- $\boxed{A. 36}$ B. $\frac{1}{6}$ C. 6 D. $\frac{1}{36}$

10. Which expression is equivalent to $\left(\frac{3^{-1}}{3^6}\right)^{-5}$?

- A. 3^{25} $\boxed{B. 3^{35}}$ C. $\frac{1}{3^{35}}$ D. $\frac{1}{3^{12}}$

11. Which expression is equivalent to $\frac{6^5 \cdot 6}{6^5}$?

- A. 36 B. 0 $\boxed{C. 6}$ D. 1

12. Which expression is equivalent to $3^{-1} \cdot (3^0)^3$?

- A. $\frac{1}{9}$ $\boxed{B. \frac{1}{3}}$ C. 3 D. 0

13. Simplify: $x^2 \cdot x$

$$x^3$$

14. Simplify: $(a^2)^4$

$$a^8$$

15. Simplify: $(p^2)^6$

$$p^{12}$$

16. Simplify: $c^5 \cdot c$

$$c^6$$

17. Simplify: $x^6 \cdot x^5$

$$x^{11}$$

18. Simplify: $(7b^4)(-9b^2)$

$$-63b^6$$

19. Simplify: $(4x^3)^3$

$$64x^9$$

20. Simplify: $(8k^3)(-8k^4)$

$$-64k^7$$

21. Simplify: $(-4r)^2$

$$16r^2$$

22. Simplify: $(10m^5)(5m^2)$

$$50m^7$$

23. Fully simplify. $6x^4y^4(8x^3y^2)$

$$48x^7y^6$$

24. Fully simplify. $x^2y^5(-7x^5y^2)$

$$-7x^7y^7$$

25. Fully simplify. $-11x^4y^5(2x^5y^2)$

$$-22x^9y^7$$

26. Fully simplify. $7x^5y^5(14x^4y^2)$

$$98x^9y^7$$

27. Fully simplify. $5x^4y^4(2x^3y^3)$

$$10x^7y^7$$

28. Fully simplify. $(3x^2y^2)^3$

$$27x^6y^6$$

29. Fully simplify. $(-5xy^2)^2$

$$\boxed{25x^2y^4}$$

30. Fully simplify. $(-2x^5y^3)^4$

$$\boxed{16x^{20}y^{12}}$$

31. Fully simplify. $(-6x^3y^5)^4$

$$\boxed{1296x^{12}y^{20}}$$

32. Fully simplify. $(2x^2y^4)^5$

$$\boxed{32x^{10}y^{20}}$$

33. Fully simplify using only positive exponents.

$$\frac{4x^3y^6}{xy^4}$$

$$\boxed{4x^2y^2}$$

34. Fully simplify using only positive exponents.

$$\frac{45x^5y^7}{9x^8y}$$

$$\boxed{\frac{5y^6}{x^3}}$$

35. Fully simplify using only positive exponents.

$$\frac{8x^4y}{20x^5y^5}$$

$$\boxed{\frac{2}{5xy^4}}$$

36. Fully simplify using only positive exponents.

$$\frac{10x^8y^2}{20x^4y^5}$$

$$\boxed{\frac{x^4}{2y^3}}$$

37. Fully simplify using only positive exponents.

$$\frac{6x^7y}{9xy^5}$$

$$\boxed{\frac{2x^6}{3y^4}}$$

38. Fully simplify using only positive exponents.

$$\frac{30x^5y^6}{6x^2y^8}$$

$$\boxed{\frac{5x^3}{y^2}}$$

39. Fully simplify.

$$(2x^3 + y^2)^2$$

$$\boxed{4x^6 + 4x^3y^2 + y^4}$$

40. Fully simplify.

$$(-6x^2y^4)^4$$

$$\boxed{1296x^8y^{16}}$$

41. Fully simplify.

$$-7y^4(3x^2y^3)$$

$$\boxed{-21x^2y^7}$$

42. Fully simplify using only positive exponents.

$$\frac{15x^5y^2}{25x^2y}$$

$$\boxed{\frac{3x^3y}{5}}$$

43. Express in simplest radical form: $\sqrt{20}$

$$\boxed{2\sqrt{5}}$$

44. Express in simplest radical form: $\sqrt{49}$

$$\boxed{7}$$

45. Express in simplest radical form: $\sqrt{112}$

$$\boxed{4\sqrt{7}}$$

46. Express in simplest radical form: $\sqrt{8}$

$$\boxed{2\sqrt{2}}$$

47. Express in simplest radical form: $\sqrt{24}$

$$\boxed{2\sqrt{6}}$$

48. Express in simplest radical form.

$$\frac{\sqrt{243}}{3}$$

$$\boxed{3\sqrt{3}}$$

49. Express in simplest radical form.

$$\frac{\sqrt{56}}{\sqrt{8}}$$

$$\boxed{\sqrt{7}}$$

50. What is the product of $\sqrt{3}$ and $8\sqrt{15}$ in simplest radical form?

$$\boxed{24\sqrt{5}}$$

51. Express in simplest radical form.

$$\sqrt{18}\sqrt{27}$$

$$\boxed{9\sqrt{6}}$$

52. What is the product of $8\sqrt{3}$ and $9\sqrt{30}$ in simplest radical form?

$$\boxed{216\sqrt{10}}$$

53. Express in simplest radical form.

$$-5\sqrt{63} + 6\sqrt{7}$$

$$\boxed{-9\sqrt{7}}$$

54. Express in simplest radical form.

$$-3\sqrt{5} - 9\sqrt{5}$$

$$\boxed{-12\sqrt{5}}$$

55. Express in simplest radical form.

$$-10\sqrt{96} - \sqrt{54}$$

$$\boxed{-43\sqrt{6}}$$

56. Express in simplest radical form.

$$-\sqrt{5} - 5\sqrt{5}$$

$$\boxed{-6\sqrt{5}}$$

57. Express in simplest radical form.

$$-7\sqrt{63} - 6\sqrt{28}$$

$$\boxed{-33\sqrt{7}}$$

58. Assuming x and y are both positive, write the following expression in simplest radical form.

$$x^3y\sqrt{4x^2y^7}$$

$$\boxed{2x^4y^4\sqrt{y}}$$

59. Assuming x and y are both positive, write the following expression in simplest radical form.

$$\sqrt{63x^2y^3}$$

$$\boxed{3xy\sqrt{7y}}$$

60. Assuming x and y are both positive, write the following expression in simplest radical form.

$$2\sqrt{12x^5y^7}$$

$$\boxed{4x^2y^3\sqrt{3xy}}$$

61. Assuming x and y are both positive, write the following expression in simplest radical form.

$$2\sqrt{75x^5y^6}$$

$$\boxed{10x^2y^3\sqrt{3x}}$$

62. Assuming x and y are both positive, write the following expression in simplest radical form.

$$y^3\sqrt{75x^2y^6}$$

$$\boxed{5xy^6\sqrt{3}}$$

63. Express in simplest radical form assuming $x > 0$.

$$\sqrt{19x^4}$$

A. $x^2\sqrt{19x}$

B. $\sqrt{19x^4}$

C. $x^2\sqrt{19}$

D. $19x^2$

64. Express in simplest radical form assuming $x > 0$.

$$\sqrt{2x^5}$$

A. $2x^3$

B. $x^2\sqrt{2x}$

C. $x^3\sqrt{2x}$

D. $\sqrt{2x^5}$

65. Express in simplest radical form assuming $x > 0$.

$$\sqrt{2x^8}$$

A. $x^4\sqrt{2x}$

B. $\sqrt{2x^8}$

C. $x^4\sqrt{2}$

D. $2x^4$

66. Express in simplest radical form assuming $x > 0$.

$$\sqrt{11x^{10}}$$

A. $11x^5$

B. $\sqrt{11x^{10}}$

C. $x^5\sqrt{11x}$

D. $x^5\sqrt{11}$

67. Express in simplest radical form assuming $x > 0$.

$$\sqrt{11x^7}$$

A. $\sqrt{11x^7}$

B. $x^3\sqrt{11x}$

C. $11x^3$

D. $x^4\sqrt{11x}$

68. Solve for x :

$$-(-3x - 8) + 2x = -10$$

$x = -3.6$

69. Solve for x :

$$6 + 3(-2x - 9) = -(6x + 3) - x$$

$$\boxed{x = 18}$$

70. Solve for x :

$$x - (x - 4) = -6 - 2x$$

$$\boxed{-5 = x}$$

71. Solve for x :

$$-3(7x - 9) = -8x - (-x + 1)$$

$$\boxed{x = 2}$$

72. Solve for x :

$$1 + 7(x + 1) = 9 - 8(x + 2)$$

$$\boxed{x = -1}$$

73. Solve for x in simplest form.

$$2 = \frac{4}{3}(4x + 6)$$

$$\boxed{x = -\frac{9}{8}}$$

74. Solve for x in simplest form.

$$7 = \frac{1}{2}(3x - 10)$$

$$\boxed{x = 8}$$

75. Solve for x in simplest form.

$$13 = \frac{3}{7}(3x + 35)$$

$$\boxed{x = -\frac{14}{9}}$$

76. Solve for x in simplest form.

$$15 = \frac{8}{5}(4x + 5)$$

$$x = \frac{35}{32}$$

77. Solve for x in simplest form.

$$3 = \frac{2}{3}(8x - 3)$$

$$x = \frac{15}{16}$$

78. Solve the system of equations using elimination:

$$-2x - 5y = 4 \text{ and } -4x - 4y = -16.$$

$$\text{Final Solution Coordinate: } (8, -4)$$

79. Solve the system of equations using elimination:

$$3x - 2y = -6 \text{ and } 8x - 3y = -30.$$

$$\text{Final Solution Coordinate: } (-6, -6)$$

80. Solve the system of equations using elimination:

$$x - y = 3 \text{ and } -3x + 9y = 33.$$

$$\text{Final Solution Coordinate: } (10, 7)$$

81. Solve the system of equations using elimination:

$$x + y = -1 \text{ and } 9x - 3y = 15.$$

$$\text{Final Solution Coordinate: } (1, -2)$$

82. Solve the system of equations using elimination:

$$-5x - 2y = 1 \text{ and } -4x - 2y = 4.$$

$$\text{Final Solution Coordinate: } (3, -8)$$

83. Solve the system by substitution.

$$y = 6x - 7$$

$$-5x + y = -6$$

$$(1, -1)$$

84. Solve the system by substitution.

$$5x - y = 21$$

$$x = 2y - 3$$

$$(5, 4)$$

85. Solve the system by substitution.

$$3x - 6 = y$$

$$-6x + y = -9$$

$$(1, -3)$$

86. Solve the system by substitution.

$$-5x - 2y = -40$$

$$y = 2x + 2$$

$$(4, 10)$$

87. Solve the system by substitution.

$$3x + y = 19$$

$$-6x - 5 = y$$

$$(-8, 43)$$

88. Express $(x + 8)^2$ as a trinomial in standard form.

$$x^2 + 16x + 64$$

89. Express $(x + 6)^2$ as a trinomial in standard form.

$$x^2 + 12x + 36$$

90. Express $(x + 3)^2$ as a trinomial in standard form.

$$x^2 + 6x + 9$$

91. Express $(x - 7)^2$ as a trinomial in standard form.

$$x^2 - 14x + 49$$

92. Express $(x + 10)^2$ as a trinomial in standard form.

$$x^2 + 20x + 100$$

93. Expand and state your answer as a polynomial in standard form.

$$(2x^2 + y^2)^2$$
$$4x^4 + 4x^2y^2 + y^4$$

94. Expand and state your answer as a polynomial in standard form.

$$(3x^2 - y^2)^2$$
$$9x^4 - 6x^2y^2 + y^4$$

95. Expand and state your answer as a polynomial in standard form.

$$(2x^4 - y^5)^2$$
$$4x^8 - 4x^4y^5 + y^{10}$$

96. Expand and state your answer as a polynomial in standard form.

$$(4x^5 + y^2)^2$$
$$16x^{10} + 8x^5y^2 + y^4$$

97. Expand and state your answer as a polynomial in standard form.

$$(3x^5 - y^4)^2$$
$$9x^{10} - 6x^5y^4 + y^8$$

98. Express as a trinomial: $(3x + 2)(x - 3)$

$$3x^2 - 7x - 6$$

99. Express as a trinomial: $(x - 6)(x - 4)$

$$x^2 - 10x + 24$$

100. Express as a trinomial: $(2x + 4)(2x + 4)$

$$4x^2 + 16x + 16$$

101. Express as a trinomial: $(2x + 2)(2x + 2)$

$$4x^2 + 8x + 4$$

102. Express as a trinomial: $(x + 10)(2x + 1)$

$$2x^2 + 21x + 10$$

103. Written as a simplified polynomial in standard form, what is the result when $(x + 5)^2$ is subtracted from $7x^2 - 10x + 4$?

$$6x^2 - 20x - 21$$

104. Written as a simplified polynomial in standard form, what is the result when $(3x - 8)^2$ is subtracted from 2?

$$-9x^2 + 48x - 62$$

105. Written as a simplified polynomial in standard form, what is the result when $(3x + 6)^2$ is subtracted from $10x + 1$?

$$-9x^2 - 26x - 35$$

106. Written as a simplified polynomial in standard form, what is the result when $(2x - 4)^2$ is subtracted from $6x^2$?

$$2x^2 + 16x - 16$$

107. Written as a simplified polynomial in standard form, what is the result when $(3x + 5)^2$ is subtracted from 4?

$$-9x^2 - 30x - 21$$

108. Express the product of $(2x + \frac{1}{5})$ and $(x - \frac{1}{4})$ as a trinomial in simplest form.

$$2x^2 - \frac{3}{10}x - \frac{1}{20}$$

109. Express the product of $(\frac{1}{2}x - 2)$ and $(\frac{1}{3}x + 1)$ as a trinomial in simplest form.

$$\frac{1}{6}x^2 - \frac{1}{6}x - 2$$

110. Express the product of $(\frac{2}{3}x - 1)$ and $(\frac{5}{6}x + 6)$ as a trinomial in simplest form.

$$\frac{5}{9}x^2 + \frac{19}{6}x - 6$$

111. Express the product of $(\frac{2}{5}x + 1)$ and $(4x - \frac{2}{5})$ as a trinomial in simplest form.

$$\frac{8}{5}x^2 + \frac{96}{25}x - \frac{2}{5}$$

112. Express the product of $(\frac{1}{2}x + 1)$ and $(\frac{6}{5}x + \frac{3}{2})$ as a trinomial in simplest form.

$$\frac{3}{5}x^2 + \frac{39}{20}x + \frac{3}{2}$$

113. Factor $x^2 - 3x - 40$

$$(x + 5)(x - 8)$$

114. Factor $x^2 - 5x + 4$

$$(x - 1)(x - 4)$$

115. Factor $x^2 - 7x - 18$

$$(x + 2)(x - 9)$$

116. Factor $x^2 + x - 42$

$$(x - 6)(x + 7)$$

117. Factor $x^2 + 6x + 8$

$$(x + 2)(x + 4)$$

118. Factor completely: $5x^2 - 9x + 4$

$$(5x - 4)(x - 1)$$

119. Factor completely: $4x^2 + 29x + 7$

$$(4x + 1)(x + 7)$$

120. Factor completely: $3x^2 - 10x + 7$

$$(3x - 7)(x - 1)$$

121. Factor completely: $3x^2 - 28x + 9$

$$(3x - 1)(x - 9)$$

122. Factor completely: $4x^2 - 24x + 27$

$$(2x - 9)(2x - 3)$$

123. Factor completely over the integers.

$$-2x^2 - x^4 + 3$$

$$-(x^2 + 3)(x + 1)(x - 1)$$

124. Factor completely over the integers.

$$-12 - x^4 + 7x^2$$

$$-(x + 2)(x - 2)(x^2 - 3)$$

125. Factor completely over the integers.

$$-x^4 - 4 + 5x^2$$

$$-(x + 2)(x - 2)(x + 1)(x - 1)$$

126. Factor completely over the integers.

$$x^5 - 6x + 5x^3$$

$$x(x + 1)(x - 1)(x^2 + 6)$$

127. Factor completely over the integers.

$$-4 - x^4 + 5x^2$$

$$-(x + 1)(x - 1)(x + 2)(x - 2)$$

128. Factor completely: $x^6 - 100y^6$

$$(x^3 + 10y^3)(x^3 - 10y^3)$$

129. Factor completely: $25 - x^6y^4$

$$(5 + x^3y^2)(5 - x^3y^2)$$

130. Factor completely: $81y^6 - 25$

$$(9y^3 + 5)(9y^3 - 5)$$

131. Factor completely: $49x^2y^6 - 4$

$$(7xy^3 + 2)(7xy^3 - 2)$$

132. Factor completely: $16x^6 - y^6$

$$(4x^3 + y^3)(4x^3 - y^3)$$

133. Write the quadratic equation in standard form:

$$1 - x^2 + 2x = x^2$$

$$\boxed{-2x^2 + 2x + 1 = 0}$$

134. Write the quadratic equation in standard form:

$$12 = 2x - 5 - x^2$$

$$\boxed{x^2 - 2x + 17 = 0}$$

135. Write the quadratic equation in standard form:

$$19 + x = -2x^2 + 4 - 2x$$

$$\boxed{2x^2 + 3x + 15 = 0}$$

136. Write the quadratic equation in standard form:

$$3x^2 - 3x = 8$$

$$\boxed{3x^2 - 3x - 8 = 0}$$

137. Write the quadratic equation in standard form:

$$-4x + 7x^2 = 2x^2 + 19$$

$$\boxed{5x^2 - 4x - 19 = 0}$$

138. Solve the quadratic by factoring.

$$x^2 + 11x - 35 = 9x$$

$$\boxed{\{x = 5, x = -7\}}$$

139. Solve the quadratic by factoring.

$$x^2 - 11x + 32 = 2$$

$$\boxed{\{x = 5, x = 6\}}$$

140. Solve the quadratic by factoring.

$$x^2 - 9x - 10 = -9x + 6$$

$$\boxed{\{x = 4, x = -4\}}$$

141. Solve the quadratic by factoring.

$$x^2 - 12 = -3$$

$$\boxed{\{x = 3, x = -3\}}$$

142. Solve the quadratic by factoring.

$$x^2 + 49 = 14x + 9$$

$$\boxed{\{x = 10, x = 4\}}$$

143. Solve the quadratic by factoring.

$$5x^2 + 4x + 11 = 10x + 10$$

$$\boxed{x = \frac{1}{5} \quad x = 1}$$

144. Solve the quadratic by factoring.

$$5x^2 = -9x - 4$$

$$\boxed{x = -\frac{4}{5} \quad x = -1}$$

145. Solve the quadratic by factoring.

$$2x^2 - 19x + 5 = -10x - 2$$

$$\boxed{x = \frac{7}{2} \quad x = 1}$$

146. Solve the quadratic by factoring.

$$3x^2 - 10x = x - 6$$

$$\boxed{x = \frac{2}{3} \quad x = 3}$$

147. Solve the quadratic by factoring.

$$5x^2 + 3x - 4 = -8x - 10$$

$x = -\frac{6}{5}$	$x = -1$
--------------------	----------

148. The difference of the square of a number and 6 is equal to 5 times that number. Find the positive solution.

6

149. The width of a rectangle is the length minus 3 units. The area of the rectangle is 40 square units. What is the width, in units, of the rectangle?

5

150. 5 times a number is 24 less than the square of that number. Find the negative solution.

-3

151. The width of a rectangle is 1 units less than the length. The area of the rectangle is 20 square units. What is the length, in units, of the rectangle?

5

152. The width of a rectangle is the length minus 2 units. The area of the rectangle is 48 square units. What is the width, in units, of the rectangle?

6

153. Use the quadratic formula to solve. Express your answer in simplest form.

$$16n^2 - 8n + 1 = 0$$

$$n = \frac{1}{4}$$

154. Use the quadratic formula to solve. Express your answer in simplest form.

$$28c^2 - 20c + 3 = 3c^2$$

$$c = \frac{3}{5}, c = \frac{1}{5}$$

155. Use the quadratic formula to solve. Express your answer in simplest form.

$$16x^2 + 8x - 3 = 0$$

$$x = \frac{1}{4}, x = \frac{-3}{4}$$

156. Use the quadratic formula to solve. Express your answer in simplest form.

$$4q^2 + 17q - 13 = 2$$

$$q = \frac{3}{4}, q = -5$$

157. Use the quadratic formula to solve. Express your answer in simplest form.

$$12p^2 - 9p - 2 = -4p$$

$$p = \frac{2}{3}, p = \frac{-1}{4}$$

158. Find the length of the third side. If necessary, round to the nearest tenth.

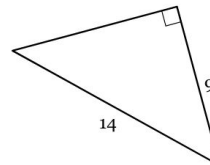

$$10.7$$

159. Find the length of the third side. If necessary, round to the nearest tenth.

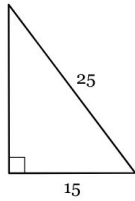

20

160. Find the length of the third side. If necessary, round to the nearest tenth.

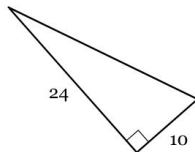

26

161. Find the length of the third side. If necessary, round to the nearest tenth.

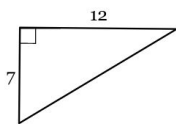

13.9

162. Find the length of the third side. If necessary, round to the nearest tenth.

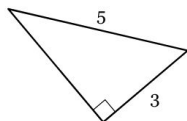

4

163. One of the legs of a right triangle measures 15 cm and the other leg measures 7 cm. Find the measure of the hypotenuse. If necessary, round to the nearest tenth.

16.6 cm

164. The hypotenuse of a right triangle measures 16 cm and one of its legs measures 14 cm. Find the measure of the other leg. If necessary, round to the nearest tenth.

7.7 cm

165. The hypotenuse of a right triangle measures 18 cm and one of its legs measures 13 cm. Find the measure of the other leg. If necessary, round to the nearest tenth.

12.4 cm

166. The hypotenuse of a right triangle measures 3 cm and one of its legs measures 1 cm. Find the measure of the other leg. If necessary, round to the nearest tenth.

2.8 cm

167. One of the legs of a right triangle measures 18 cm and its hypotenuse measures 19 cm. Find the measure of the other leg. If necessary, round to the nearest tenth.

6.1 cm

168. $ABCD$ is a kite, so $\overline{AC} \perp \overline{DB}$ and $DE = EB$. Calculate the length of \overline{AC} , to the nearest tenth of a centimeter.

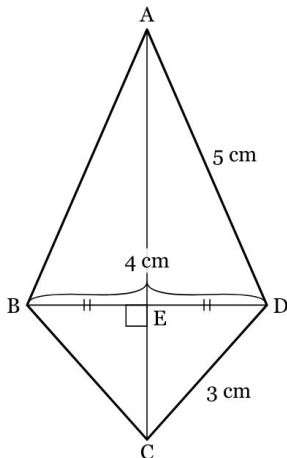

$AC \approx 6.8$ cm

169. A straw is placed inside a rectangular box that is 7 inches by 8 inches by 10 inches, as shown. If the straw fits *exactly* into the box diagonally from the bottom left corner to the top right back corner, how long is the straw? Leave your answer in simplest radical form.

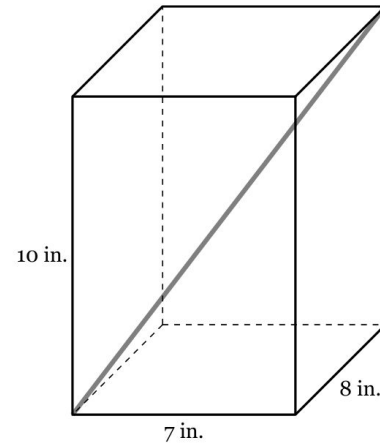

$\sqrt{213}$ in.

170. A straw is placed inside a rectangular box that is 2 inches by 4 inches by 1 inches, as shown. If the straw fits *exactly* into the box diagonally from the bottom left corner to the top right back corner, how long is the straw? Leave your answer in simplest radical form.

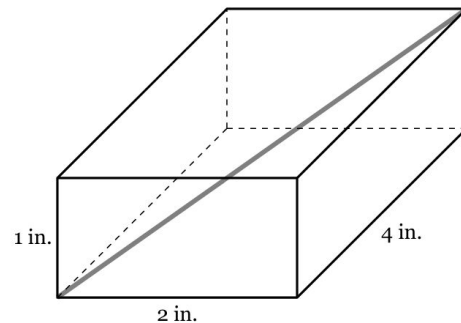

$\sqrt{21}$ in.

171. A straw is placed inside a rectangular box that is 8 inches by 3 inches by 7 inches, as shown. If the straw fits *exactly* into the box diagonally from the bottom left corner to the top right back corner, how long is the straw? Leave your answer in simplest radical form.

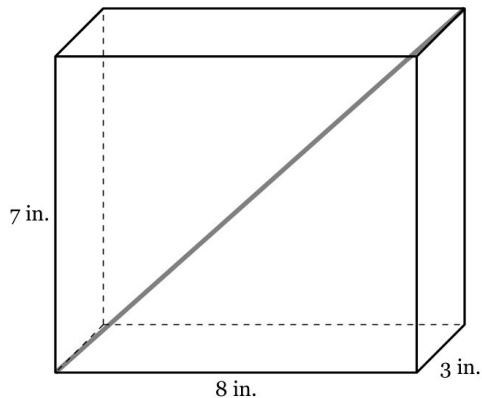

$$\sqrt{122} \text{ in.}$$

172. $ABCD$ is a kite, so $\overline{AC} \perp \overline{DB}$ and $DE = EB$. Calculate the length of \overline{AC} , to the nearest tenth of a centimeter.

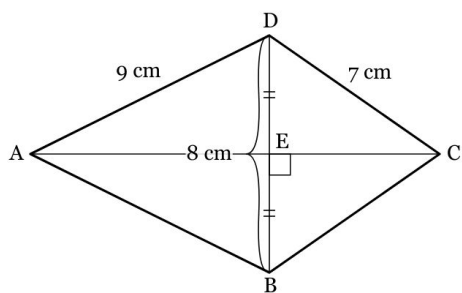

$$AC \approx 13.8 \text{ cm}$$

173. Graph a right triangle with the points $(-7, -9)$ and $(2, 3)$ forming the hypotenuse. Using the sides, find the distance between the two points in simplest radical form.

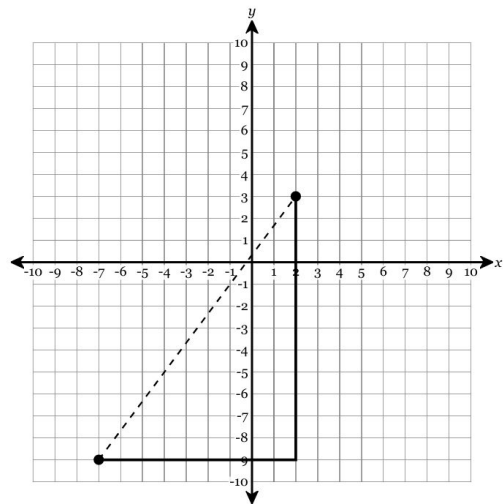

Leg 1: 9 Leg 2: 12 Hypotenuse: 15

174. Graph a right triangle with the points $(5, 6)$ and $(-2, 9)$ forming the hypotenuse. Using the sides, find the distance between the two points in simplest radical form.

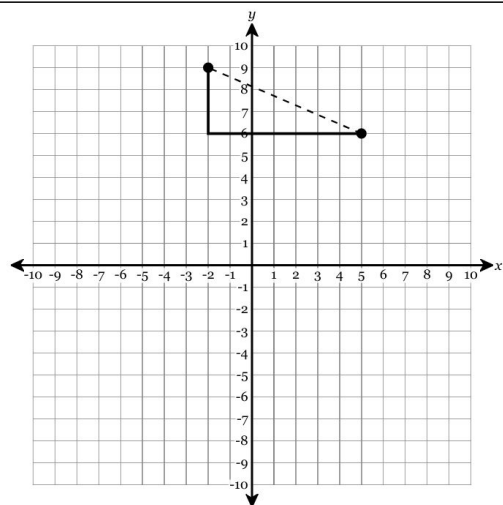

Leg 1: 7 Leg 2: 3 Hypotenuse: $\sqrt{58}$

175. Graph a right triangle with the points $(4, -7)$ and $(7, -4)$ forming the hypotenuse. Using the sides, find the distance between the two points in simplest radical form.

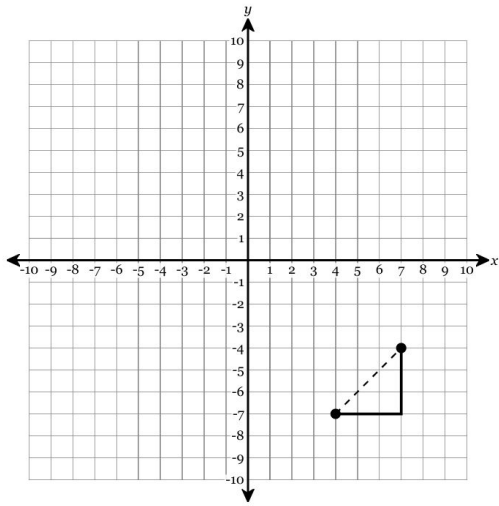

Leg 1: 3 Leg 2: 3 Hypotenuse: $3\sqrt{2}$

177. Graph a right triangle with the points $(-1, 4)$ and $(4, -8)$ forming the hypotenuse. Using the sides, find the distance between the two points in simplest radical form.

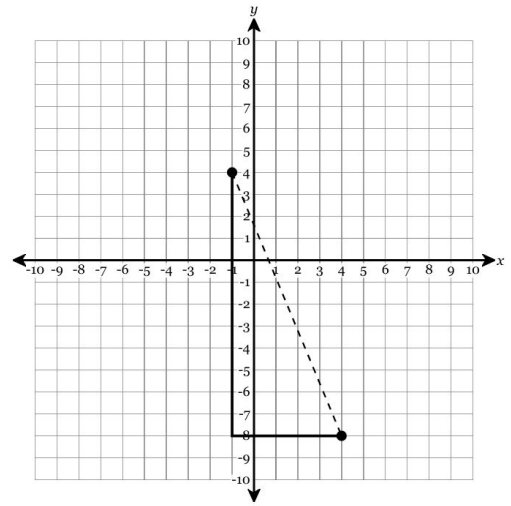

Leg 1: 5 Leg 2: 12 Hypotenuse: 13

176. Graph a right triangle with the points $(3, -2)$ and $(-3, 6)$ forming the hypotenuse. Using the sides, find the distance between the two points in simplest radical form.

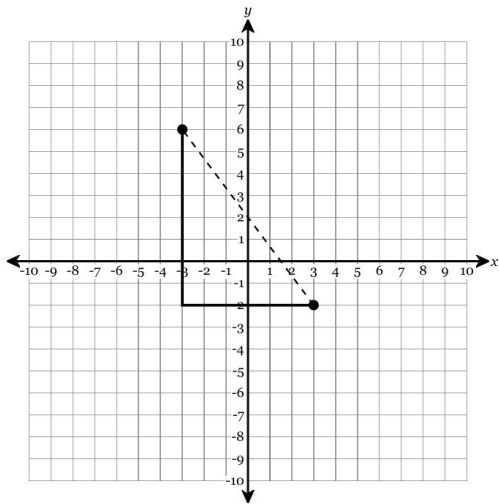

Leg 1: 6 Leg 2: 8 Hypotenuse: 10

178. Find the distance between the two points in simplest radical form.

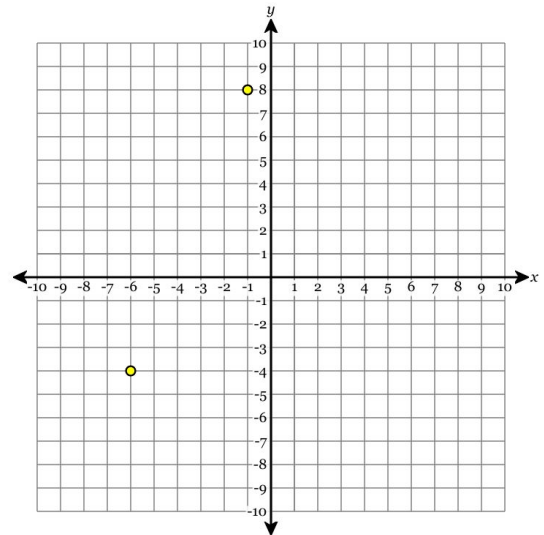

13

179. Find the distance between the two points in simplest radical form.

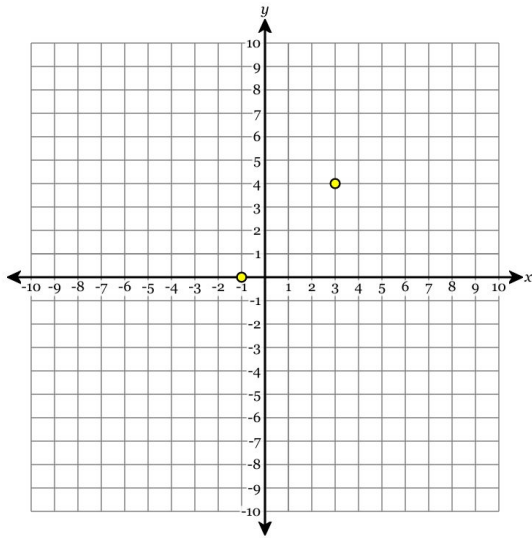

$$4\sqrt{2}$$

180. Find the distance between the two points in simplest radical form.

$$(4, 5) \text{ and } (-2, 7)$$

$$2\sqrt{10}$$

181. Find the distance between the two points in simplest radical form.

$$(1, 0) \text{ and } (7, -8)$$

$$10$$

182. Find the distance between the two points in simplest radical form.

$$(-6, -9) \text{ and } (-2, -5)$$

$$4\sqrt{2}$$

183. Given $l \parallel m \parallel n$, find the value of x .

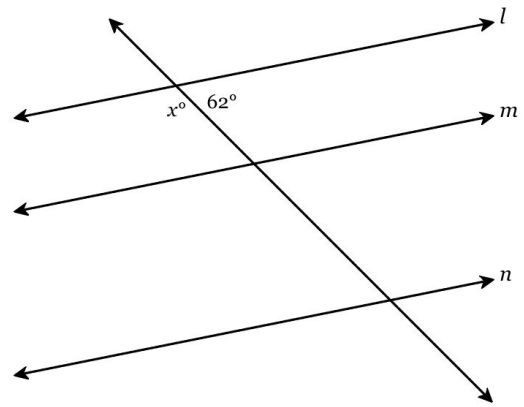

$$x = 118$$

184. Given $m \parallel n$, find the value of x .

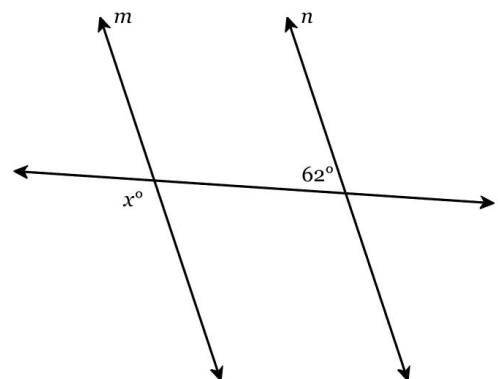

$$x = 118$$

185. Given $m \parallel n$, find the value of x and y .

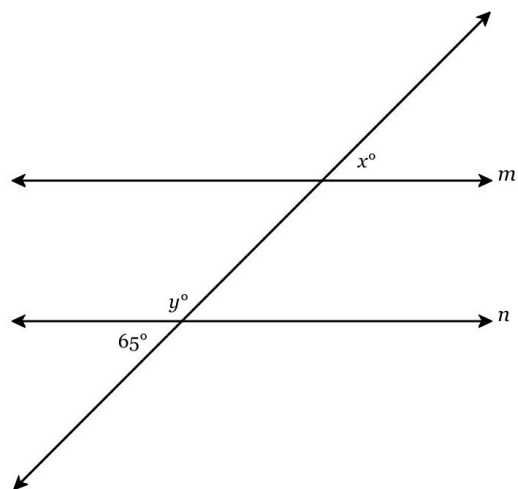

$$\{\}$$

186. Given $m \parallel n$, find the value of x .

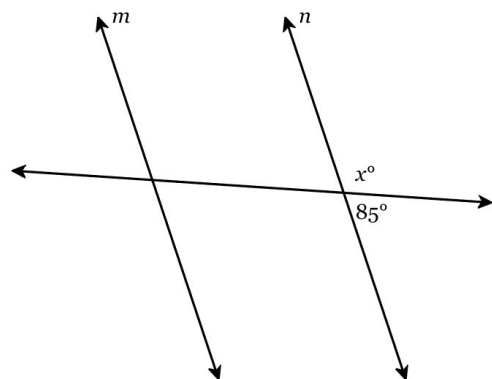

$$x = 95$$

187. Given $l \parallel m \parallel n$, find the value of x .

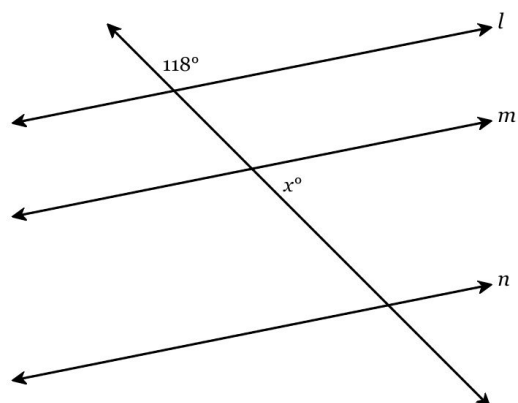

$$x = 62$$

188. Given $l \parallel m \parallel n$, find the value of x .

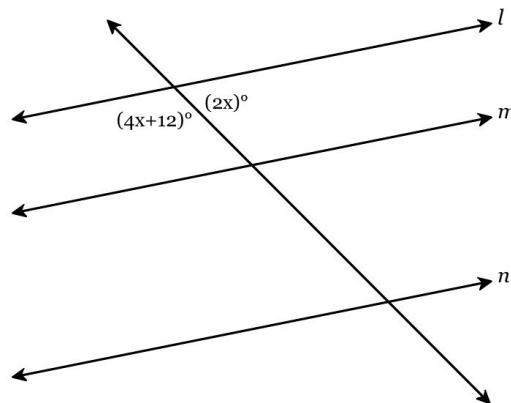

$$x = 28$$

189. Given $m \parallel n$, find the value of x and y .

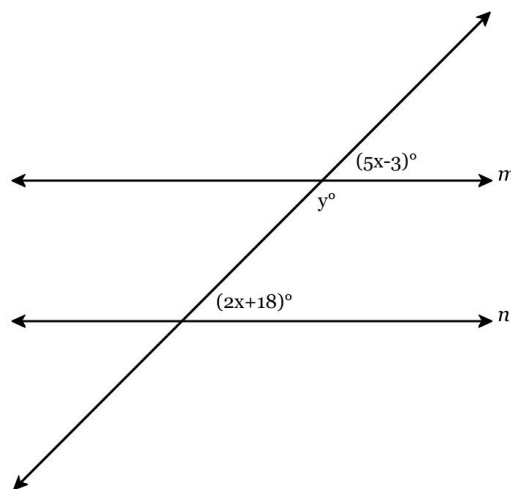

$$x = 7 \quad y = 148$$

190. Given $m \parallel n$, find the value of x .

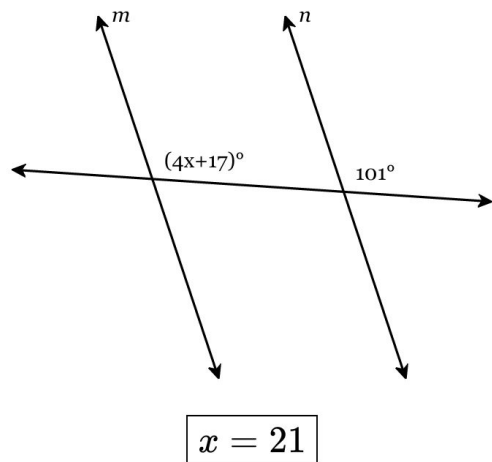

191. Given $l \parallel m \parallel n$, find the value of x .

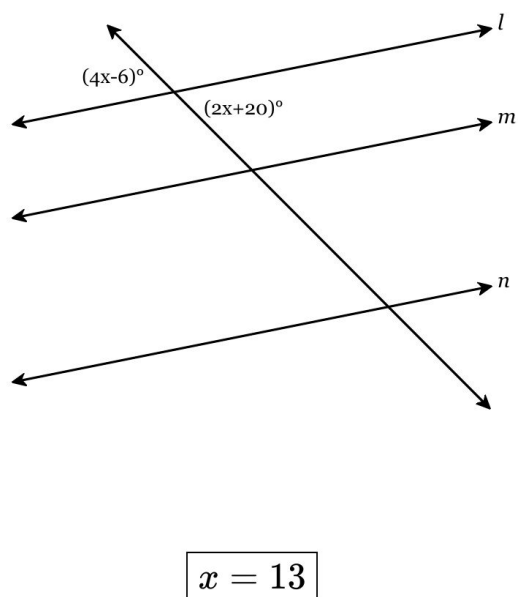

192. Given $l \parallel m \parallel n$, find the value of x .

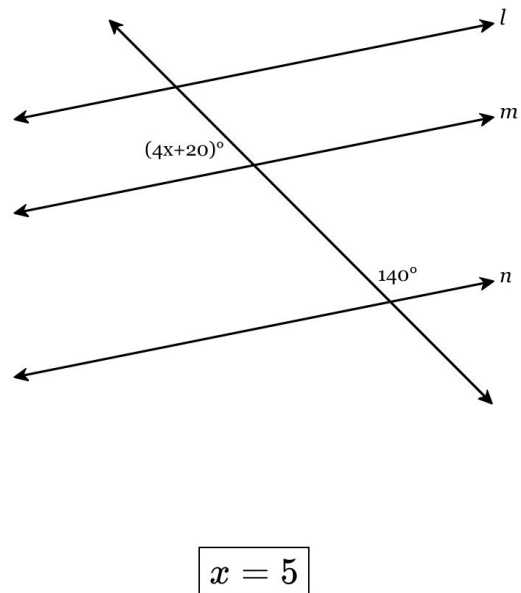

193. The measures of the angles of a triangle are shown in the figure below. Solve for x .

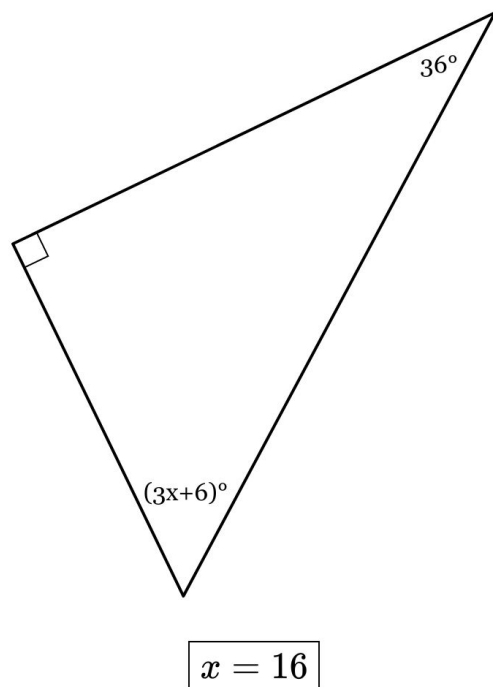

194. The measures of the angles of a triangle are shown in the figure below. Solve for x .

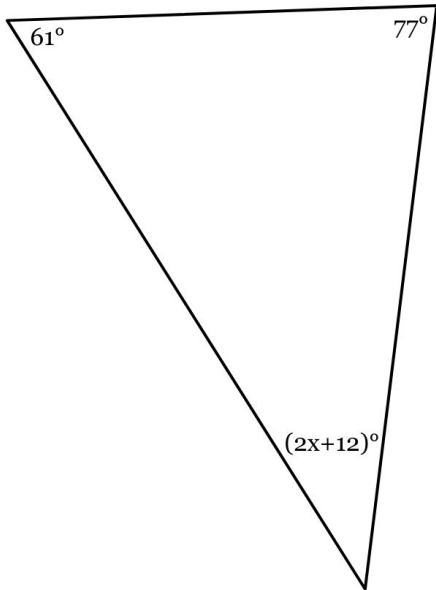

$$x = 15$$

195. The measures of the angles of a triangle are shown in the figure below. Solve for x .

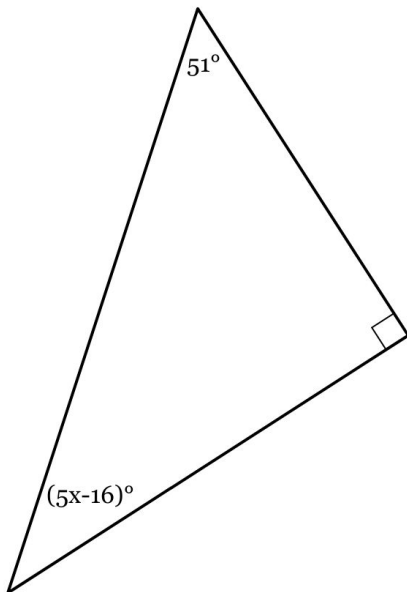

$$x = 11$$

196. The measures of the angles of a triangle are shown in the figure below. Solve for x .

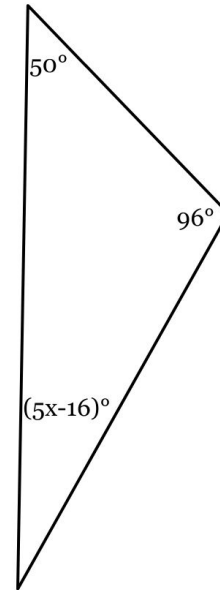

$$x = 10$$

197. The measures of the angles of a triangle are shown in the figure below. Solve for x .

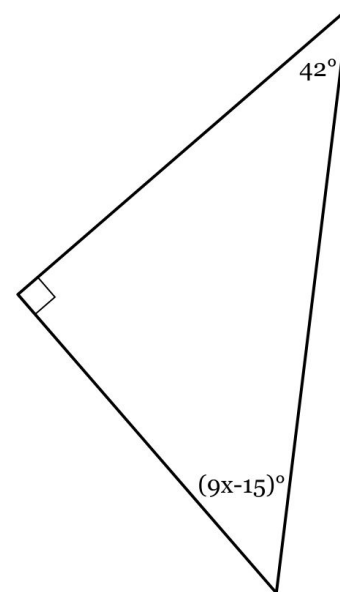

$$x = 7$$

198. A side of the triangle below has been extended to form an exterior angle of 145° . Find the value of x .

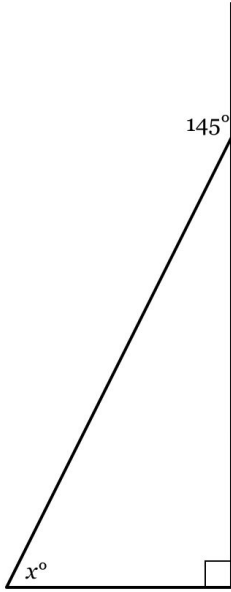

$$x = 55$$

199. A side of the triangle below has been extended to form an exterior angle of 72° . Find the value of x .

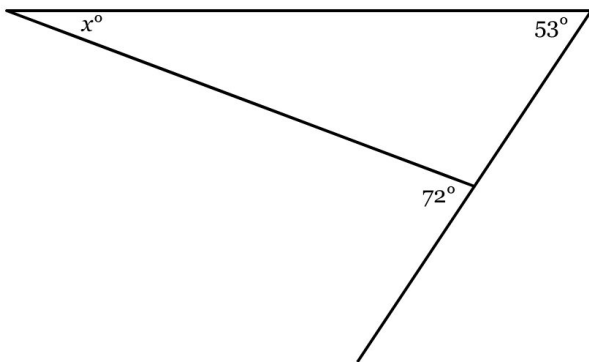

$$x = 19$$

200. A side of the triangle below has been extended to form an exterior angle of 78° . Find the value of x .

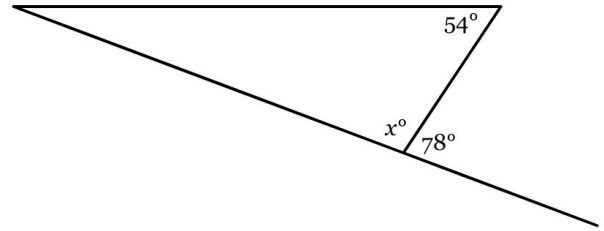

$$x = 102$$

201. A side of the triangle below has been extended to form an exterior angle of 145° . Find the value of x .

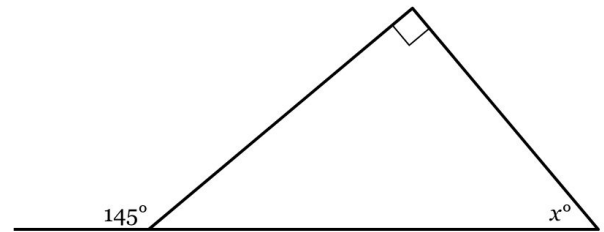

$$x = 55$$

202. A side of the triangle below has been extended to form an exterior angle of 128° . Find the value of x .

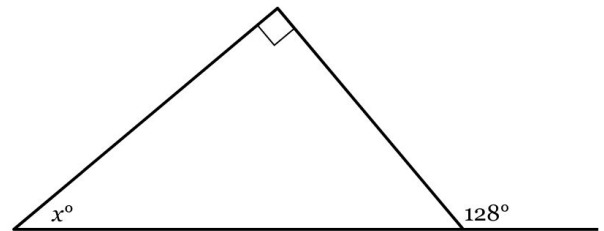

$$x = 38$$

203. Find the slope of the line represented by the equation below.

$$y = -5 + 2x$$

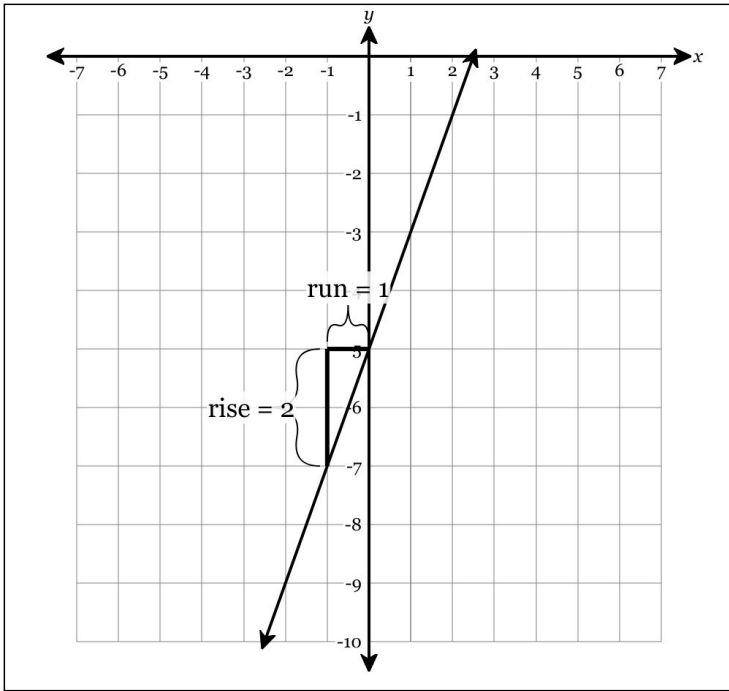

204. Find the y-intercept of the line represented by the equation below.

$$y = -5 - 4x$$

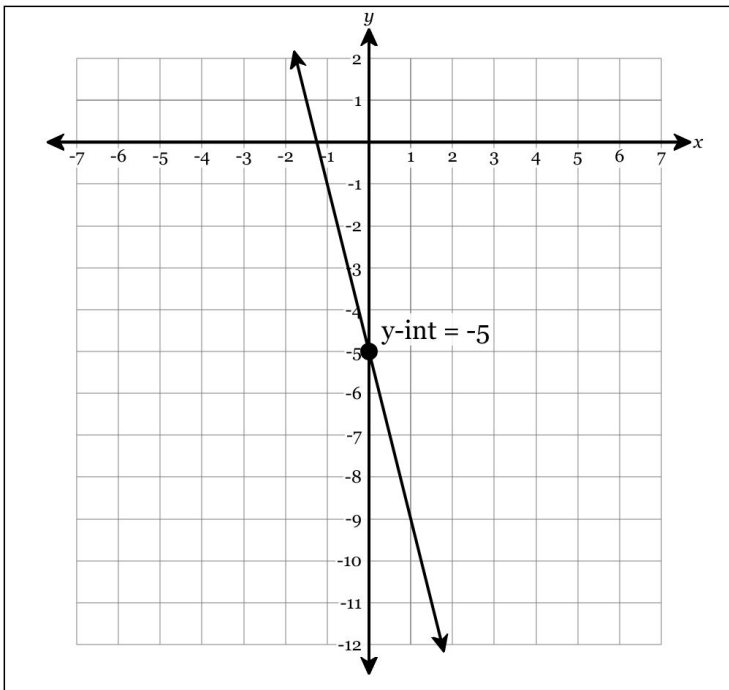

205. Find the slope of the line represented by the equation below.

$$\frac{5}{4}x - 1 = y$$

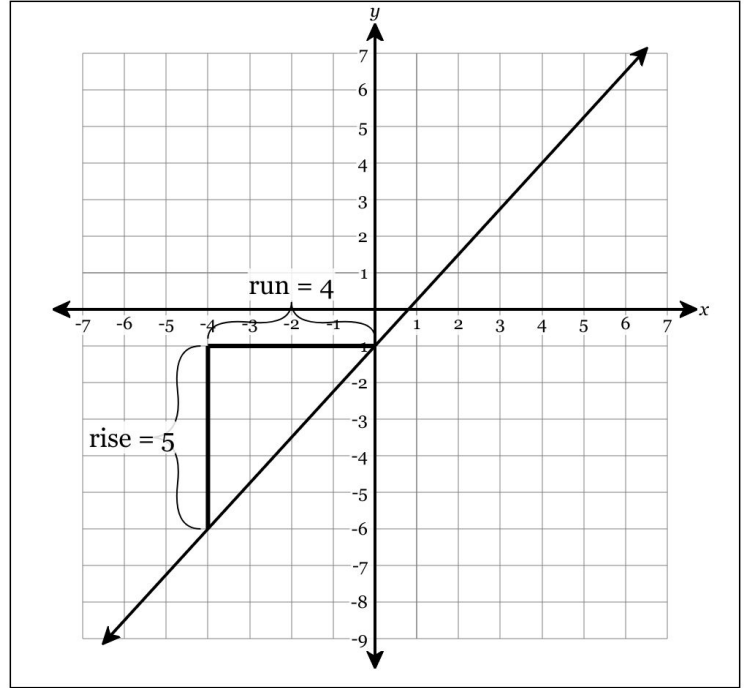

206. Find the y-intercept of the line represented by the equation below.

$$y = x - 4$$

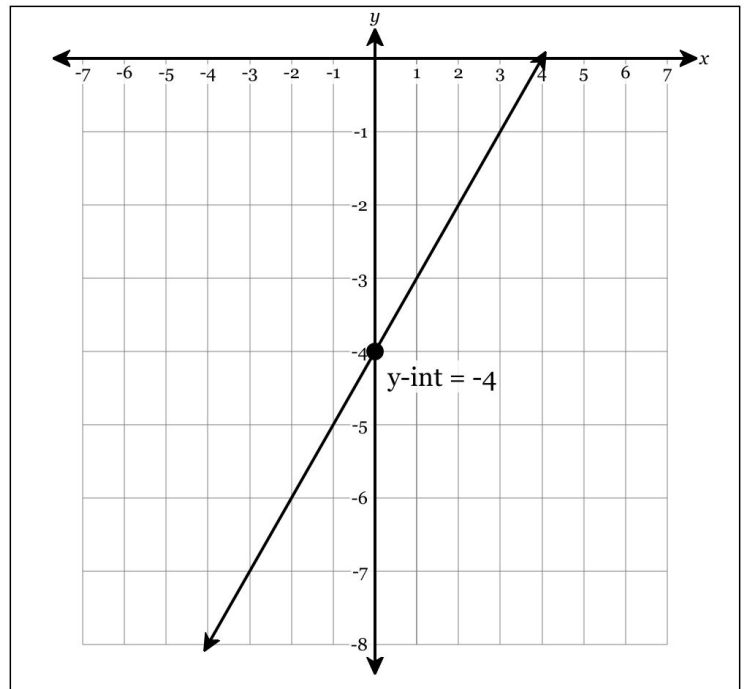

207. Find the y-intercept of the line represented by the equation below.

$$5 + x = y$$

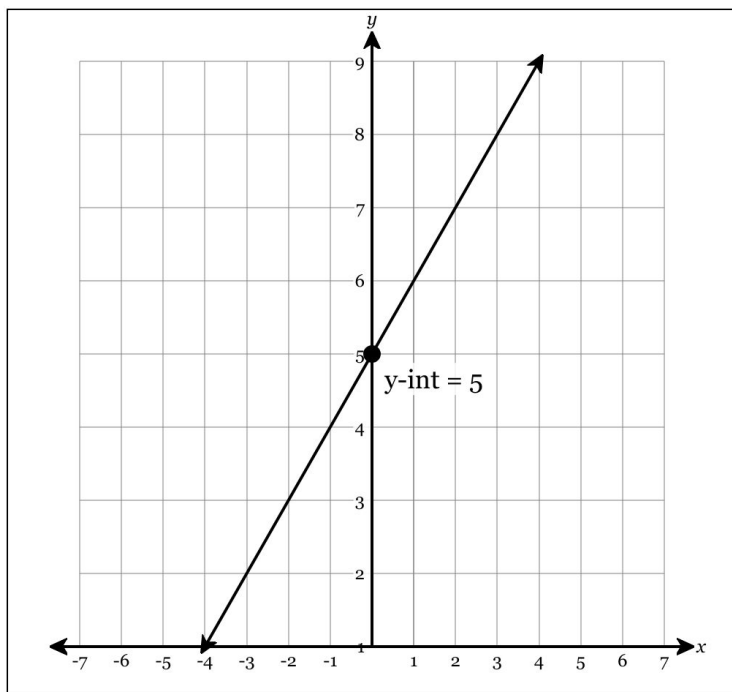

209. Find the slope of the line represented by the equation below.

$$y - 4x = -2$$

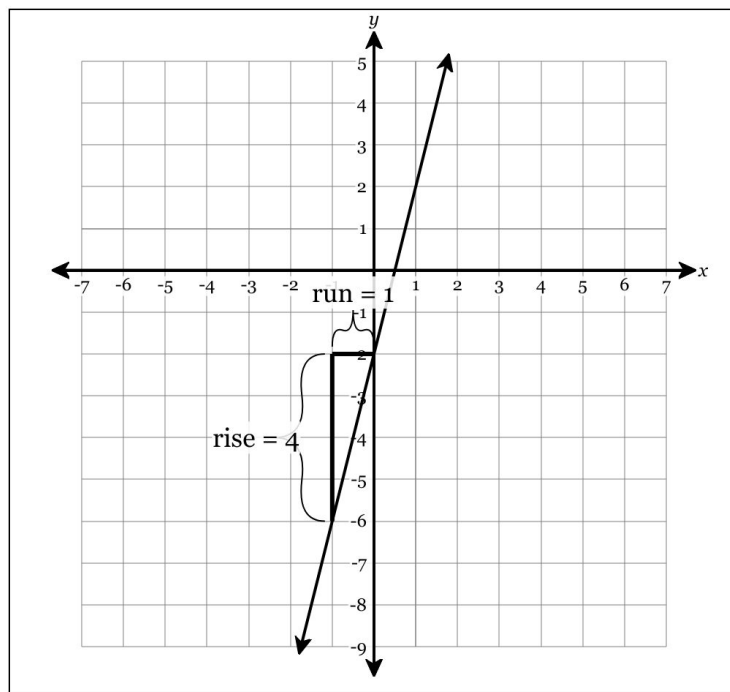

208. Find the y-intercept of the line represented by the equation below.

$$y + x = 2$$

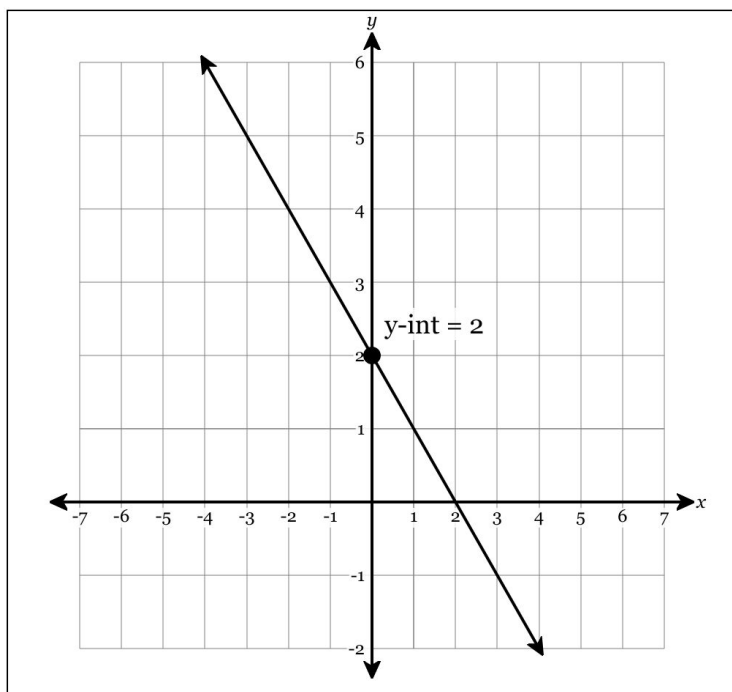

210. Find the slope of the line represented by the equation below.

$$-x - y = -3$$

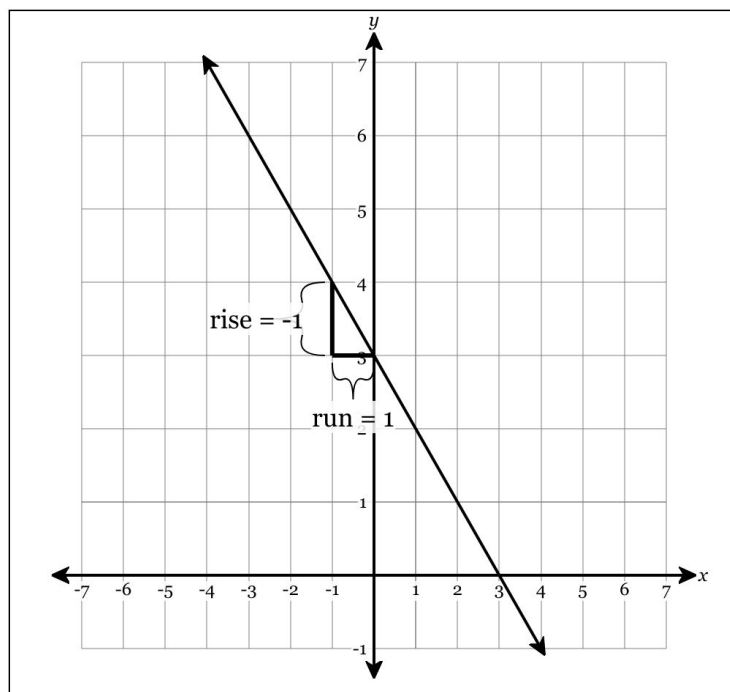

211. Find the slope of the line represented by the equation below.

$$5y + 4x = 5$$

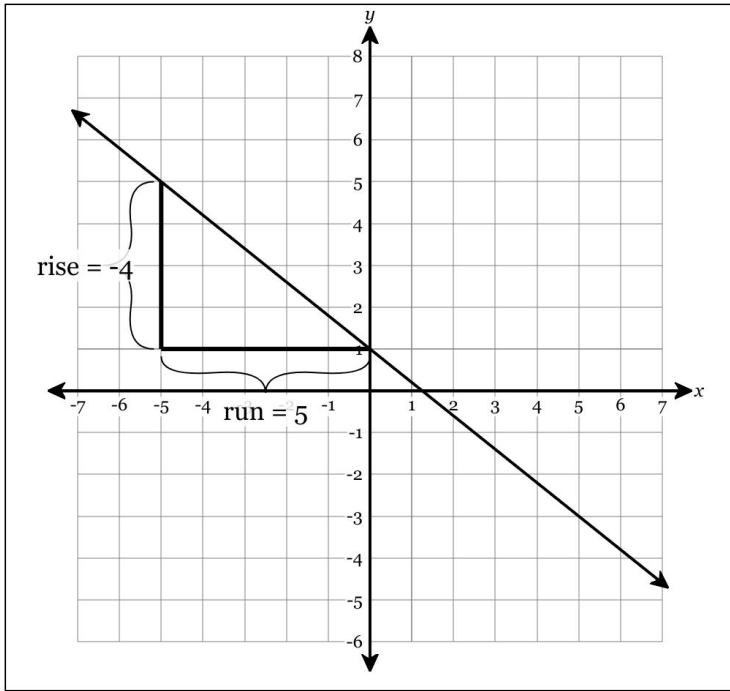

212. Find the slope of the line represented by the equation below.

$$5y + 2x = -15$$

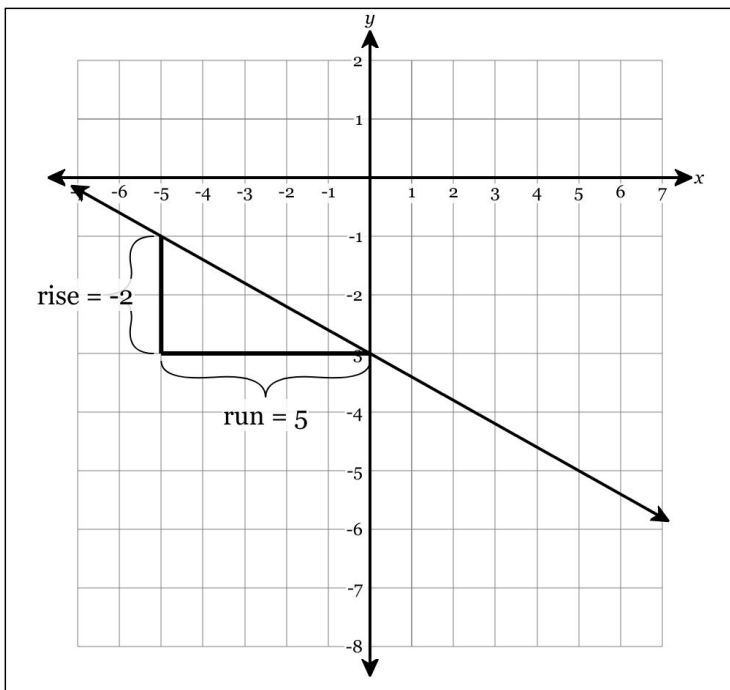

213. What is the slope of the line that passes through the points $(-7, 0)$ and $(5, 0)$? Write your answer in *simplest form*.

0

214. What is the slope of the line that passes through the points $(-10, 3)$ and $(-18, 1)$? Write your answer in *simplest form*.

$\frac{1}{4}$

215. What is the slope of the line that passes through the points $(-10, 5)$ and $(5, 8)$? Write your answer in *simplest form*.

$\frac{1}{5}$

216. What is the slope of the line that passes through the points $(4, -6)$ and $(19, -6)$? Write your answer in *simplest form*.

0

217. What is the slope of the line that passes through the points $(-8, -1)$ and $(-5, 0)$? Write your answer in *simplest form*.

$\frac{1}{3}$

218. Graph the following features:

- Y-intercept = 1
- Slope = $\frac{2}{3}$

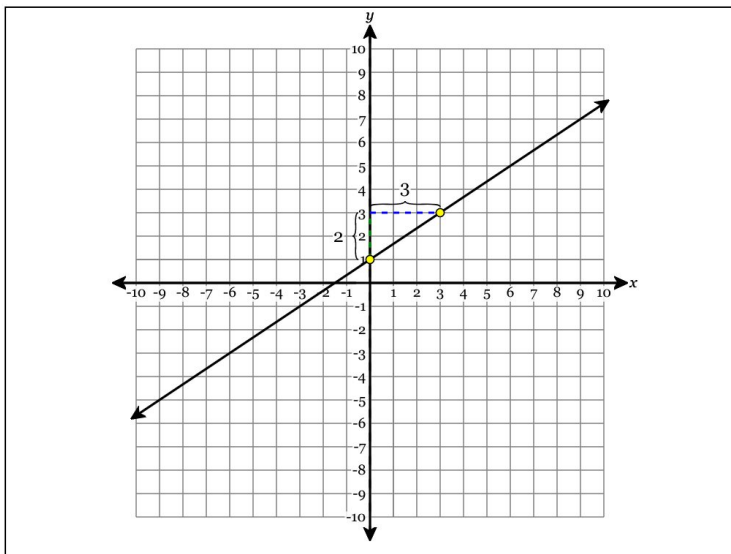

220. Graph the following features:

- Slope = $\frac{4}{3}$
- Y-intercept = 3

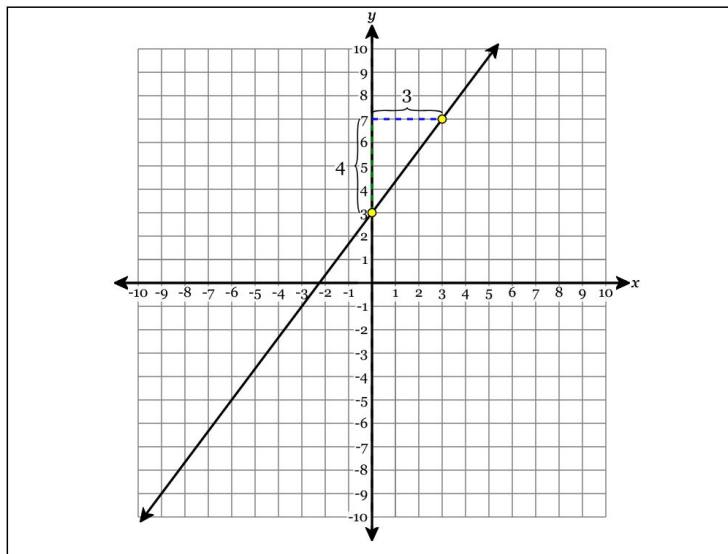

219. Graph the following features:

- Slope = $-\frac{5}{3}$
- Y-intercept = 1

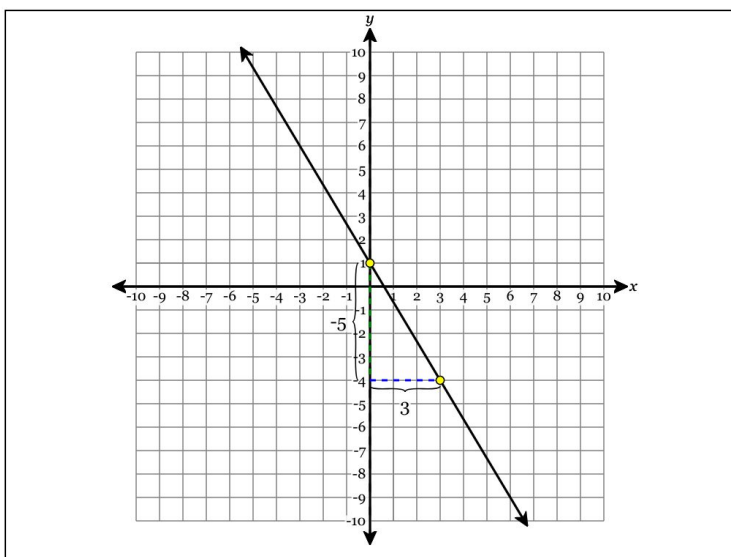

221. Graph the following features:

- Y-intercept = 3
- Slope = 3

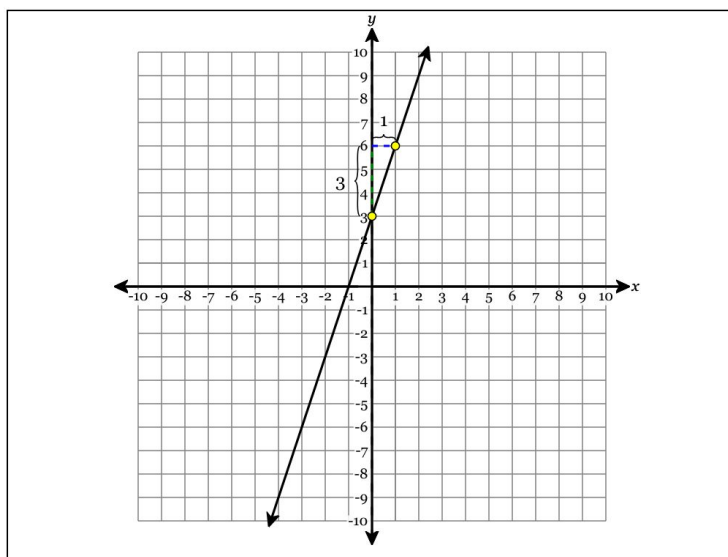

222. Graph the following features:

- Y-intercept = 3
- Slope = -3

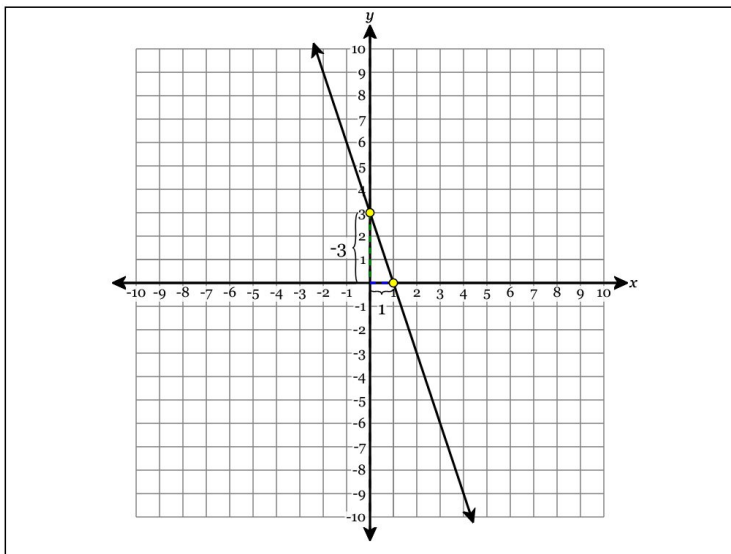

223. Solve for x . Round to the nearest tenth, if necessary.

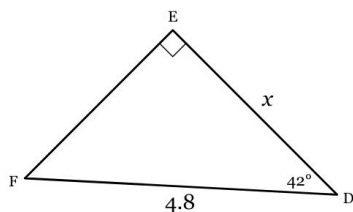

$$x = 3.6$$

224. Solve for x . Round to the nearest tenth, if necessary.

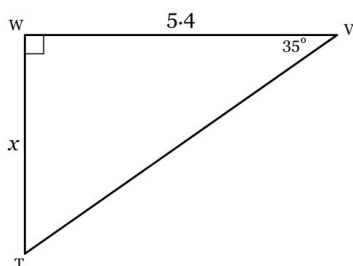

$$x = 3.8$$

225. Solve for x . Round to the nearest tenth, if necessary.

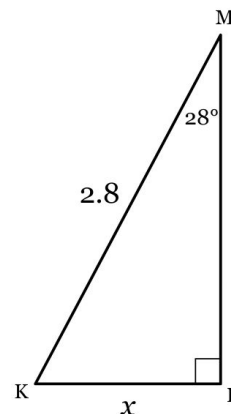

$$x = 1.3$$

226. Solve for x . Round to the nearest tenth, if necessary.

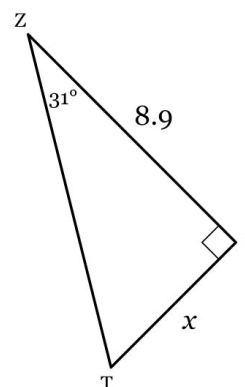

$$x = 5.3$$

227. Solve for x . Round to the nearest tenth, if necessary.

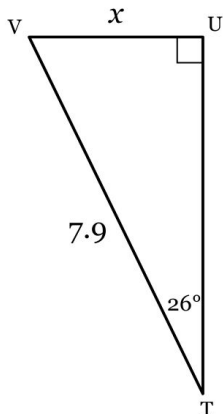

$$x = 3.5$$

228. Solve for x . Round to the nearest tenth of a degree, if necessary.

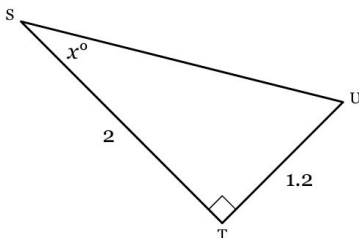

$$x = 31^\circ$$

229. Solve for x . Round to the nearest tenth of a degree, if necessary.

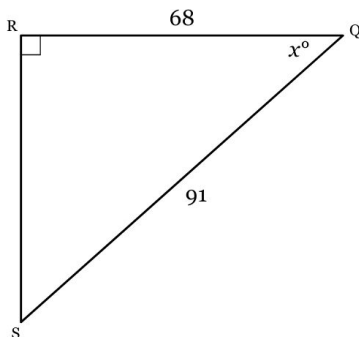

$$x = 41.6^\circ$$

230. Solve for x . Round to the nearest tenth of a degree, if necessary.

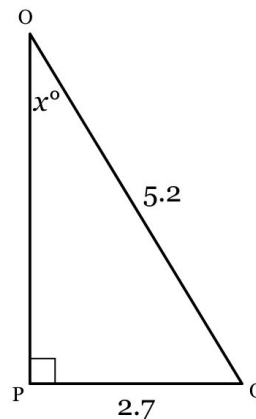

$$x = 31.3^\circ$$

231. Solve for x . Round to the nearest tenth of a degree, if necessary.

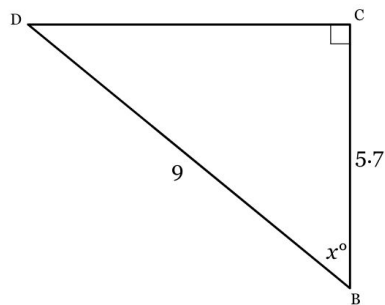

$$x = 50.7^\circ$$

232. Solve for x . Round to the nearest tenth of a degree, if necessary.

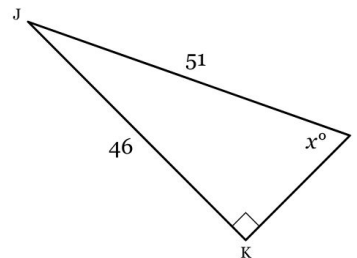

$$x = 64.4^\circ$$

233. From the observation deck of a skyscraper, Colton measures a 51° angle of depression to a ship in the harbor below. If the observation deck is 1117 feet high, what is the horizontal distance from the base of the skyscraper out to the ship? Round your answer to the nearest hundredth of a foot if necessary.

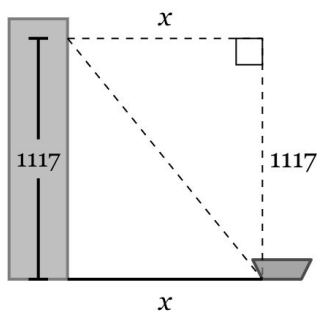

904.53 feet

234. From a hot-air balloon, Victoria measures a 38° angle of depression to a landmark that's 640 feet away, measuring horizontally. What's the balloon's vertical distance above the ground? Round your answer to the nearest tenth of a foot if necessary.

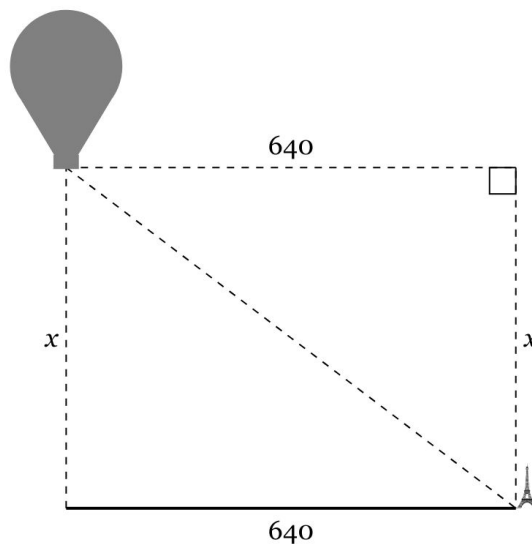

500 feet

235. Gabriel is flying a kite, holding his hands a distance of 2.5 feet above the ground and letting all the kite's string out. He measures the angle of elevation from his hand to the kite to be 21° . If the string from the kite to his hand is 80 feet long, how many feet is the kite above the ground? Round your answer to the nearest tenth of a foot if necessary.

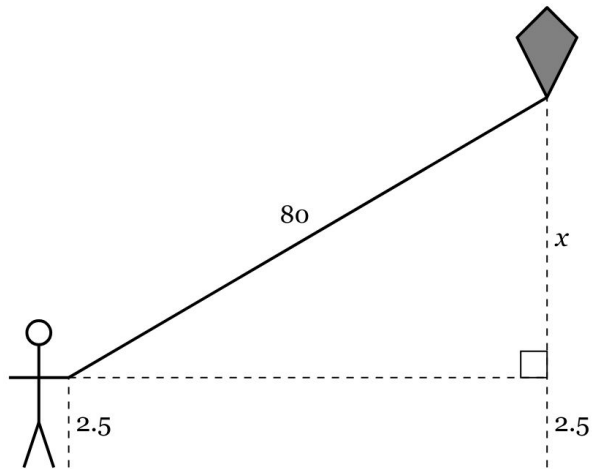

31.2 feet

236. An electrician leans an extension ladder against the outside wall of a house so that it reaches an electric box 21 feet up. The ladder makes an angle of 62° with the ground. Find the length of the ladder. Round your answer to the nearest hundredth of a foot if necessary.

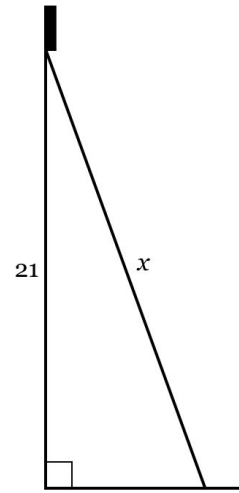

23.78 feet

237. From his eye, which stands 1.53 meters above the ground, Gabriel measures the angle of elevation to the top of a prominent skyscraper to be 43° . If he is standing at a horizontal distance of 230 meters from the base of the skyscraper, what is the height of the skyscraper? Round your answer to the nearest hundredth of a meter if necessary.

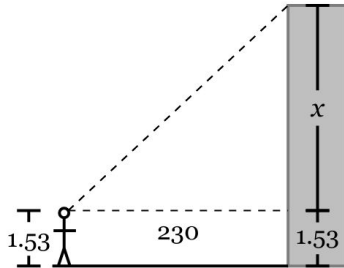

216.01 meters