

1. Simplify the expression below using order of operations.

$$\left(-2 \times (-7) \times (-6)^1\right)^1 - 10$$

2. Simplify the expression below using order of operations.

$$\frac{5 - 5}{4 + (-6)} + \frac{-3 + 3}{2^2 - 8}$$

3. Simplify the expression below using order of operations.

$$[(2 \times (-6)) - (2 + (-1))] + 5^3 - (-2)$$

4. Simplify the expression below using order of operations.

$$\left((-2)^3 - 2 + (-5)^3\right) - 10 + 9 \times (-1)$$

5. Simplify the expression below using order of operations.

$$\left(3^3 + (-2)^3 \div (-4)\right) + (-9) + (-6)$$

6. Use an exponent to condense the expression below. Then compute.

$$6 \times 6 \times 6 \times 6 \times 6$$

7. Use multiplication to expand the expression below. Then compute.

$$10^6$$

8. Use multiplication to expand the expression below.
Then compute.

$$7^5$$

9. Use multiplication to expand the expression below.
Then compute.

$$5^2$$

10. Use multiplication to expand the expression below.
Then compute.

$$0^4$$

11. Use multiplication to expand the expression below.
Then compute.

$$(-5)^4$$

12. Use an exponent to condense the expression below.
Then compute.

$$-3 \times -3 \times -3 \times -3$$

13. Use multiplication to expand the expression below.
Then compute.

$$(-1)^4$$

14. Use multiplication to expand the expression below.
Then compute.

$$(-8)^4$$

15. Use multiplication to expand the expression below.
Then compute.

$$(-10)^2$$

16. Circle all the factors of 63 in the hundreds chart below.

1	2	3	4	5	6	7	8	9	10
11	12	13	14	15	16	17	18	19	20
21	22	23	24	25	26	27	28	29	30
31	32	33	34	35	36	37	38	39	40
41	42	43	44	45	46	47	48	49	50
51	52	53	54	55	56	57	58	59	60
61	62	63	64	65	66	67	68	69	70
71	72	73	74	75	76	77	78	79	80
81	82	83	84	85	86	87	88	89	90
91	92	93	94	95	96	97	98	99	100

17. Circle all the factors of 8 in the hundreds chart below.

1	2	3	4	5	6	7	8	9	10
11	12	13	14	15	16	17	18	19	20
21	22	23	24	25	26	27	28	29	30
31	32	33	34	35	36	37	38	39	40
41	42	43	44	45	46	47	48	49	50
51	52	53	54	55	56	57	58	59	60
61	62	63	64	65	66	67	68	69	70
71	72	73	74	75	76	77	78	79	80
81	82	83	84	85	86	87	88	89	90
91	92	93	94	95	96	97	98	99	100

18. Circle all the factors of 36 in the hundreds chart below.

1	2	3	4	5	6	7	8	9	10
11	12	13	14	15	16	17	18	19	20
21	22	23	24	25	26	27	28	29	30
31	32	33	34	35	36	37	38	39	40
41	42	43	44	45	46	47	48	49	50
51	52	53	54	55	56	57	58	59	60
61	62	63	64	65	66	67	68	69	70
71	72	73	74	75	76	77	78	79	80
81	82	83	84	85	86	87	88	89	90
91	92	93	94	95	96	97	98	99	100

19. Circle all the factors of 9 in the hundreds chart below.

1	2	3	4	5	6	7	8	9	10
11	12	13	14	15	16	17	18	19	20
21	22	23	24	25	26	27	28	29	30
31	32	33	34	35	36	37	38	39	40
41	42	43	44	45	46	47	48	49	50
51	52	53	54	55	56	57	58	59	60
61	62	63	64	65	66	67	68	69	70
71	72	73	74	75	76	77	78	79	80
81	82	83	84	85	86	87	88	89	90
91	92	93	94	95	96	97	98	99	100

20. Circle all the factors of 60 in the hundreds chart below.

1	2	3	4	5	6	7	8	9	10
11	12	13	14	15	16	17	18	19	20
21	22	23	24	25	26	27	28	29	30
31	32	33	34	35	36	37	38	39	40
41	42	43	44	45	46	47	48	49	50
51	52	53	54	55	56	57	58	59	60
61	62	63	64	65	66	67	68	69	70
71	72	73	74	75	76	77	78	79	80
81	82	83	84	85	86	87	88	89	90
91	92	93	94	95	96	97	98	99	100

21. What is the prime factorization of 99?

22. What is the prime factorization of 525?

23. What is the prime factorization of 41?

24. What is the prime factorization of 264?

25. What is the prime factorization of 22?

26. What is the greatest common factor of 18, 24, and 48?

27. What is the greatest common factor of 27 and 9?

28. What is the greatest common factor of 18, 12, and 9?

29. What is the greatest common factor of 36, 30, and 6?

30. What is the greatest common factor of 50 and 40?

31. What is the least common multiple of 8, 10, and 15?

32. What is the least common multiple of 3 and 6?

33. What is the least common multiple of 3 and 5?

34. What is the least common multiple of 3, 5, and 6?

35. What is the least common multiple of 2, 3, and 10?

36. Scale the numerator and the denominator down by a factor of 12 (divide) to write a fraction equivalent to $\frac{36}{48}$.

37. Scale the numerator and the denominator up by a factor of 3 (multiply) to write a fraction equivalent to $\frac{3}{4}$.

38. Scale the numerator and the denominator down by a factor of 5 (divide) to write a fraction equivalent to $\frac{30}{35}$.

39. Scale the numerator and the denominator up by a factor of **3** (multiply) to write a fraction equivalent to $\frac{6}{7}$.

40. Scale the numerator and the denominator up by a factor of **6** (multiply) to write a fraction equivalent to $\frac{9}{10}$.

41. Evaluate the expression shown below and write your answer **as a fraction** in simplest form.

$$\frac{2}{3} + \frac{3}{10}$$

42. Evaluate the expression shown below and write your answer **as a fraction** in simplest form.

$$\frac{1}{2} - \frac{7}{16}$$

43. Evaluate the expression shown below and write your answer **as a fraction** in simplest form.

$$\frac{3}{4} + \frac{1}{10}$$

44. Evaluate the expression shown below and write your answer **as a fraction** in simplest form.

$$\frac{7}{9} - \frac{2}{9}$$

45. Evaluate the expression shown below and write your answer **as a fraction** in simplest form.

$$\frac{5}{6} - \frac{4}{9}$$

46. Perform the operation below. Express your answer as a mixed number in simplest form.

$$3\frac{3}{10} - 1\frac{1}{5}$$

47. Perform the operation below. Express your answer as a mixed number in simplest form.

$$4\frac{3}{4} - 1\frac{9}{10}$$

48. Perform the operation below. Express your answer as a mixed number in simplest form.

$$2\frac{1}{2} + 2\frac{2}{3}$$

49. Perform the operation below. Express your answer as a mixed number in simplest form.

$$3\frac{3}{10} - 2\frac{1}{4}$$

50. Perform the operation below. Express your answer as a mixed number in simplest form.

$$3\frac{2}{5} + 1\frac{3}{10}$$

51. Perform the operation and simplify the answer fully.

$$\frac{9}{7} \cdot \frac{1}{4}$$

52. Perform the operation and simplify the answer fully.

$$\frac{5}{8} \cdot \frac{2}{3}$$

53. Perform the operation and simplify the answer fully.

$$\frac{4}{5} \div \frac{3}{2}$$

54. Perform the operation and simplify the answer fully.

$$\frac{1}{\frac{4}{5} \cdot 2}$$

55. Perform the operation and simplify the answer fully.

$$\frac{4}{9} \cdot \frac{4}{3}$$

56. Evaluate the expression shown below and write your answer as a fraction or mixed number in simplest form.

$$-\frac{7}{8} \cdot -\frac{3}{4}$$

57. Evaluate the expression shown below and write your answer as a fraction or mixed number in simplest form.

$$4\frac{7}{8} \times -\frac{4}{5}$$

58. Evaluate the expression shown below and write your answer as a fraction or mixed number in simplest form.

$$-\frac{10}{9} \div -\frac{8}{5}$$

59. Evaluate the expression shown below and write your answer as a fraction or mixed number in simplest form.

$$-3\frac{1}{3} \times 2\frac{3}{4}$$

60. Evaluate the expression shown below and write your answer as a fraction or mixed number in simplest form.

$$-4\frac{3}{5} \div \frac{1}{2}$$

61. Solve for d . Express your answer in simplest radical form if necessary.

$$d = (\sqrt[3]{-23})^3$$

62. Solve for c . Express your answer in simplest radical form if necessary.

$$c = \sqrt{23.6} \cdot \sqrt{23.6}$$

63. Solve for a . Express your answer in simplest radical form if necessary.

$$35 = a^2$$

64. Solve for d . Express your answer in simplest radical form if necessary.

$$d^3 = 50$$

65. Solve for y . Express your answer in simplest radical form if necessary.

$$40 = y^2$$

66. Determine if $0.989889888988889888889\dots$ is rational or irrational and give a reason for your answer.

The number $0.989889888988889888889\dots$ is

_____ because

word bank 1

word bank 2

This word bank also applies to questions 67 - 70.

Word bank 1: (a) rational, (b) irrational

Word bank 2: (a) it is a decimal that repeats, (b) it is a decimal that terminates, (c) it is the square root of a non-perfect square, (d) it is the square root of a perfect square, (e) it is a decimal that does not repeat or terminate

67. Determine if $\sqrt{49}$ is rational or irrational and give a reason for your answer.

The number $\sqrt{49}$ is _____ because

word bank 1

word bank 2

68. Determine if $\sqrt{64}$ is rational or irrational and give a reason for your answer.

The number $\sqrt{64}$ is _____ because

word bank 1

word bank 2

69. Determine if $0.393993999399993999993\dots$ is rational or irrational and give a reason for your answer.

The number $0.393993999399993999993\dots$ is

_____ because

word bank 1

word bank 2

70. Determine if $\sqrt{72}$ is rational or irrational and give a reason for your answer.

The number $\sqrt{72}$ is _____ because

word bank 1

word bank 2

71. Write an expression for 39 less than 40. Do not solve.

72. Write an expression for the product of 7 and 2. Do not solve.

73. Write an expression for 28 divided by 7. Do not solve.

74. Write an expression for the sum of 22 and 27. Do not solve.

75. Write an expression for the quotient of 9 and 1. Do not solve.

76. Identify the variable in the expression below.

$$7 + 2y$$

77. How many terms are written in the expression below?

$$9q$$

78. Identify the constant term in the expression below.

$$1 + 8c$$

79. Identify the coefficient in the expression below.

$$10y + 4$$

80. Identify the coefficient in the expression below.

$$3x + 5$$

81. The width of a rectangle measures $(7u + 3)$ centimeters, and its length measures $(9u + 6)$ centimeters. Which expression represents the perimeter, in centimeters, of the rectangle?

- A. $9 + 16u$ B. $20u + 30$
C. $10u + 15$ D. $32u + 18$

82. A triangle has side lengths of $(7t + 10u)$ centimeters, $(3t + 6v)$ centimeters, and $(8v - 7u)$ centimeters. Which expression represents the perimeter, in centimeters, of the triangle?

- A. $uv + 17tu + 9tv$ B. $10t + v + 16u$
C. $14v + 3u + 10t$ D. $18tv + 9uv$

83. Which expression is equivalent to $k + 9k - 7k$?

- A. $k + 2$ B. $-k$ C. $1 + 2k$ D. $3k$

84. Which expression is equivalent to $-6r + 8 - 5r + 5$?

- A. $-r + 13$ B. 2
C. $-11r + 13$ D. $2r$

85. Which expression is equivalent to $-6 + h - 9h$?

- A. $-14h$ B. $-5 - 9h$
C. $-16h$ D. $-8h - 6$

86. Rewrite in simplest terms:

$$-4(-3b - 8b + 6) - 8b$$

87. Rewrite in simplest terms: $-3(-6v + 8) + v$

88. Rewrite in simplest terms: $3m - 10(-8m + 8)$

89. Rewrite in simplest terms:

$$5(-10s + 4t) + 10t - 7(-3t - 8s)$$

90. Rewrite in simplest terms:

$$-2(-8v + 5) + 9(8v - 5)$$

91. Convert 0.007 to a fraction in simplest form and a percent.

92. Convert $\frac{39}{50}$ to a decimal and a percent.

93. Convert 43.6% to a fraction in simplest form and a decimal.

94. Convert $\frac{17}{60}$ to a decimal and a percent.

95. Convert 0.424 to a fraction in simplest form and a percent.

96. 259 is what percent of 740?

97. What is 21% of 500?

98. What is 36% of 25?

99. 276 is what percent of 300?

100. What is 54% of 650?

101. Amira goes to a restaurant and the subtotal on the bill was x dollars. A tax of 8% is applied to the bill. Amira decides to leave a tip of 22% on the entire bill (including the tax). Write an expression in terms of x that represents the total amount that Amira paid.

102. Benjamin bought stock in a company two years ago that was worth x dollars. During the first year that he owned the stock, it increased by 39%. During the second year the value of the stock decreased by 11%. Write an expression in terms of x that represents the value of the stock after the two years have passed.

103. Colton goes to a restaurant and the subtotal on the bill was x dollars. A tax of 9% is applied to the bill. Colton decides to leave a tip of 16% on the entire bill (including the tax). Write an expression in terms of x that represents the total amount that Colton paid.

104. Brianna goes to a restaurant and the subtotal on the bill was x dollars. A tax of 7% is applied to the bill. Brianna decides to leave a tip of 25% on the entire bill (including the tax). Write an expression in terms of x that represents the total amount that Brianna paid.

105. Isaiah bought stock in a company two years ago that was worth x dollars. During the first year that he owned the stock, it decreased by 10%. During the second year the value of the stock decreased by 14%. Write an expression in terms of x that represents the value of the stock after the two years have passed.

106. Last year at a certain high school, there were 100 ninth graders on the honor roll and 145 tenth graders on the honor roll. This year, the number of ninth graders on the honor roll increased by 25% and the number of tenth graders on the honor roll increased by 20%. By what percentage did the total number of students on the honor roll increase? Round your answer *to the nearest tenth* (if necessary).

107. An investor has an account with stock from two different companies. Last year, his stock in Company A was worth \$3840 and his stock in Company B was worth \$2690. The stock in Company A has increased 5% since last year and the stock in Company B has increased 20%. What was the total percentage increase in the investor's stock account? Round your answer *to the nearest tenth* (if necessary).

108. Last year at a certain high school, there were 135 ninth graders on the honor roll and 125 tenth graders on the honor roll. This year, the number of ninth graders on the honor roll decreased by 20% and the number of tenth graders on the honor roll decreased by 24%. By what percentage did the total number of students on the honor roll decrease? Round your answer *to the nearest tenth* (if necessary).

109. Last year at a certain high school, there were 50 ninth graders on the honor roll and 84 tenth graders on the honor roll. This year, the number of ninth graders on the honor roll increased by 22% and the number of tenth graders on the honor roll increased by 25%. By what percentage did the total number of students on the honor roll increase? Round your answer *to the nearest tenth* (if necessary).

110. Last year at a certain high school, there were 150 ninth graders on the honor roll and 85 tenth graders on the honor roll. This year, the number of ninth graders on the honor roll decreased by 24% and the number of tenth graders on the honor roll decreased by 20%. By what percentage did the total number of students on the honor roll decrease? Round your answer *to the nearest tenth* (if necessary).

111. Simplify to a single power of 5:

$$\frac{5^8}{5^6}$$

112. Simplify to a single power of 2:

$$2^3 \cdot 2$$

113. Simplify to a single power of 5:

$$(5^3)^2$$

114. Simplify to a single power of 2:

$$(2^4)^2$$

115. Simplify to a single power of 2:

$$\frac{2^5}{2}$$

116. Which expression is equivalent to $\frac{5^{-7}}{5^{-7}}$?

- A. 1 B. 0 C. $\frac{1}{5}$ D. 5^{14}

117. Which expression is equivalent to $(2^{-1})^3$?

- A. 2^4 B. $\frac{1}{2^3}$ C. 2^2 D. 1

118. Which expression is equivalent to $3^{-4} \times 3^6$?

- A. 3^3 B. $\frac{1}{3^{24}}$ C. $\frac{1}{3^2}$ D. 3^2

119. Which expression is equivalent to $4^5 \cdot 4^{-2}$?

- A. $\frac{1}{4^7}$
B. 4^4
C. 4^7
D. 4^3

120. Which expression is equivalent to $5^{-2} \cdot 5^{-1}$?

- A. $\frac{1}{125}$ B. $\frac{1}{5}$ C. $\frac{1}{25}$ D. 25

121. Simplify: $(-2q)^3$

122. Simplify: $(-m^3)(-9m)$

123. Simplify: $(-4x)(10x^3)$

124. Simplify: $(2d^5)^2$

125. Simplify: $(-2q)^2$

126. Fully simplify. $15x^4y^4(-5x^3y^5)$

127. Fully simplify. $-7x^2(9x^2y^4)$

128. Fully simplify. $x^2y^4(-4x^4y^2)$

129. Fully simplify. $y^4(-7x^2)$

130. Fully simplify. $5x^4y^4(2x^3y^3)$

131. Fully simplify. $(5xy)^5$

132. Fully simplify. $(-2x^2y^5)^3$

133. Fully simplify. $(-5x^2y^5)^2$

134. Fully simplify. $(6xy^5)^3$

135. Fully simplify. $(5x^4y^3)^3$

136. What value of x is the solution to the equation below?

$$-5 + x = -8$$

137. What value of x is the solution to the equation below?

$$-3 = \frac{x}{10}$$

138. What value of x is the solution to the equation below?

$$5x = -45$$

139. What value of x is the solution to the equation below?

$$-4 = x + 11$$

140. What value of x is the solution to the equation below?

$$18 = -2x$$

141. Solve for b .

$$-59 = -3b - 32$$

142. Solve for y .

$$9 = 5 - \frac{y}{3}$$

143. Solve for y .

$$-\frac{y}{3} + 19 = 33$$

144. Solve for c .

$$-6c + 36 = -48$$

145. Solve for a .

$$30 = 26 - \frac{a}{6}$$

146. Solve. $3(2x + 9) = 33$

147. Solve. $2(3z + 1) = -4$

148. Solve. $2(2z - 8) = -52$

149. Solve. $3(2z - 5) = -27$

150. Solve. $2(2x + 7) = 42$

151. Identify the highlighted part of circle O or P shown below.

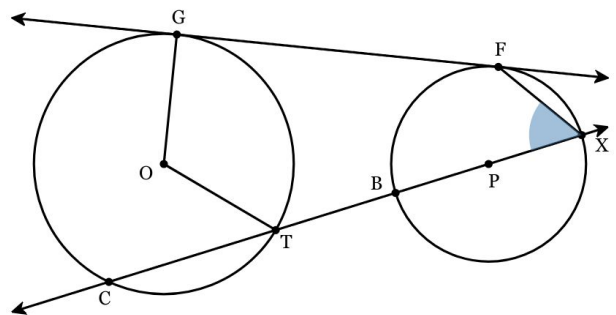

- A. central angle
- B. tangent
- C. inscribed angle
- D. radius

152. Which of the segments below is a diameter?

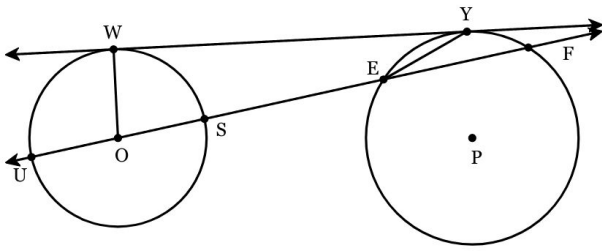

- A. \overline{OW}
- B. \overline{SE}
- C. \overline{US}
- D. \overline{EY}

153. Identify the highlighted part of circle O or P shown below.

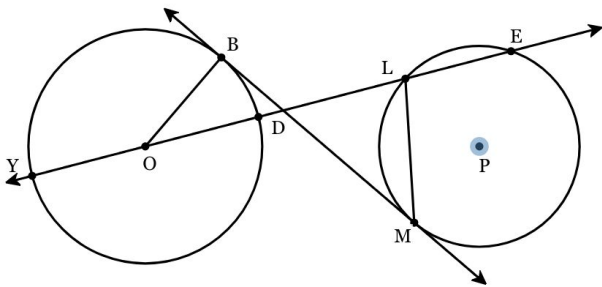

- A. center
- B. radius
- C. central angle
- D. chord

154. Identify the highlighted part of circle O or P shown below.

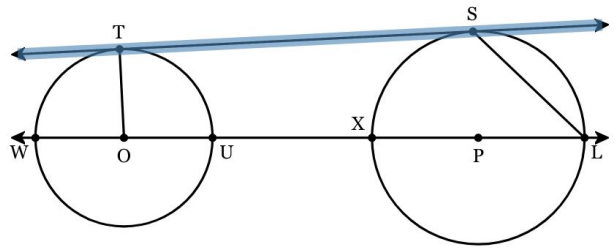

- A. inscribed angle
- B. diameter
- C. secant
- D. tangent

155. Identify the highlighted part of circle O or P shown below.

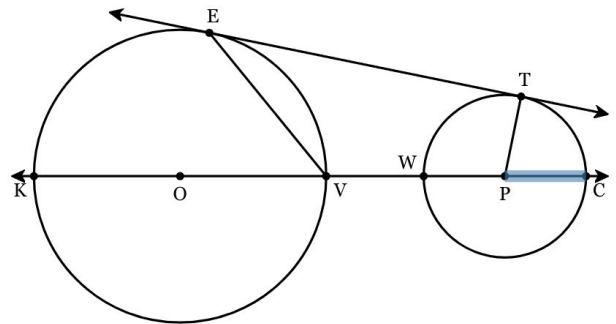

- A. radius
- B. secant
- C. central angle
- D. chord

156. The diameter of a circle is 10 in. Find its circumference in terms of π .

157. The radius of a circle is 19 m. Find its circumference in terms of π .

158. The diameter of a circle is 11 ft. Find its circumference in terms of π .

159. The radius of a circle is 19 in. Find its circumference in terms of π .

160. The radius of a circle is 9 m. Find its circumference in terms of π .

161. The radius of a circle is 15.3 in. Find the circumference *to the nearest tenth*.

162. The diameter of a circle is 170 in. Find the circumference *to the nearest whole number*.

163. The radius of a circle is 9 cm. Find the circumference *to the nearest whole number*.

164. The radius of a circle is 18.2 cm. Find the circumference *to the nearest whole number*.

165. The radius of a circle is 2.8 cm. Find the circumference *to the nearest whole number*.

166. The radius of a circle is 20 in. Find its area in terms of π .

167. The diameter of a circle is 18 cm. Find its area in terms of π .

168. The radius of a circle is 15 ft. Find its area in terms of π .

169. The radius of a circle is 20 m. Find its area in terms of π .

170. The radius of a circle is 7 ft. Find its area in terms of π .

171. The diameter of a circle is 10 m. Find its area *to the nearest tenth*.

172. The radius of a circle is 9 m. Find its area *to the nearest whole number*.

173. The diameter of a circle is 35 cm. Find its area *to the nearest whole number*.

174. The diameter of a circle is 11 cm. Find its area *to the nearest tenth*.

175. The diameter of a circle is 41 ft. Find its area *to the nearest whole number*.

176. Does the triangle below appear to be scalene, isosceles, or equilateral? Select the best answer choice below and explain why.

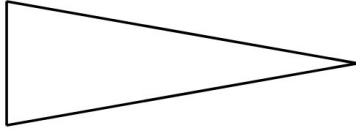

The triangle appears to be _____ because

_____.

Word Bank 1:

- 1) scalene
- 2) isosceles
- 3) equilateral

Word Bank 2:

- 1) all sides have different lengths
- 2) two sides have equal length
- 3) three sides have equal length

177. Does the triangle below appear to be scalene, isosceles, or equilateral? Select the best answer choice below and explain why.



The triangle appears to be _____ because

_____.

Word Bank 1:

- 1) scalene
- 2) isosceles
- 3) equilateral

Word Bank 2:

- 1) all sides have different lengths
- 2) one pair of sides has the same length
- 3) all sides have the same length

178. Does the triangle below appear to be scalene, isosceles, or equilateral? Select the best answer choice below and explain why.

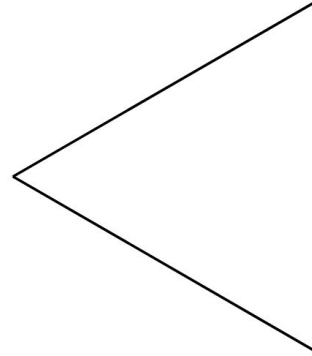

The triangle appears to be _____ because

_____.

Word Bank 1:

- 1) scalene
- 2) isosceles
- 3) equilateral

Word Bank 2:

- 1) no sides have equal length
- 2) one pair of sides has the same length
- 3) three sides have equal length

179. Does the triangle below appear to be scalene, isosceles, or equilateral? Select the best answer choice below and explain why.

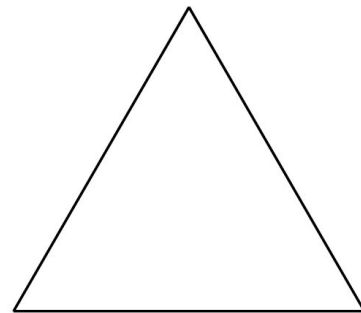

The triangle appears to be _____ because

_____.

Word Bank 1:

- 1) scalene
- 2) isosceles
- 3) equilateral

Word Bank 2:

- 1) no sides have equal length
- 2) one pair of sides has the same length
- 3) three sides have equal length

180. Does the triangle below appear to be scalene, isosceles, or equilateral? Select the best answer choice below and explain why.



The triangle appears to be _____ because

_____.

Word Bank 1:

- 1) scalene
- 2) isosceles
- 3) equilateral

Word Bank 2:

- 1) no sides have equal length
- 2) one pair of sides has the same length
- 3) all sides have the same length

181. Does the triangle below appear to be acute, right, or obtuse? Fill in the sentence below to answer and explain why.

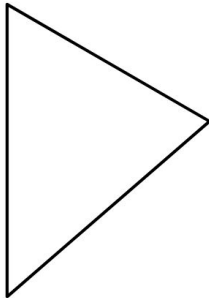

The triangle appears to be _____ because

_____.

Word Bank 1:

- 1) acute
- 2) right
- 3) obtuse

Word Bank 2:

- 1) all angles are acute
- 2) one angle measures 90°
- 3) one angle measures more than 90°

182. Does the triangle below appear to be acute, right, or obtuse? Fill in the sentence below to answer and explain why.



The triangle appears to be _____ because

_____.

Word Bank 1:

- 1) acute
- 2) right
- 3) obtuse

Word Bank 2:

- 1) it has 3 acute angles
- 2) it has a right angle
- 3) it has one obtuse angle

183. Does the triangle below appear to be acute, right, or obtuse? Fill in the sentence below to answer and explain why.

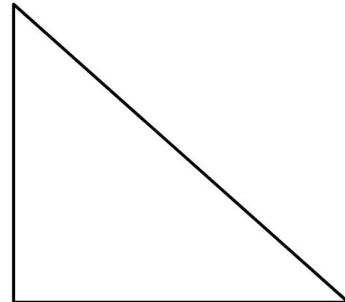

The triangle appears to be _____ because

_____.

Word Bank 1:

- 1) acute
- 2) right
- 3) obtuse

Word Bank 2:

- 1) it has 3 acute angles
- 2) one angle measures 90°
- 3) it has one obtuse angle

184. Does the triangle below appear to be acute, right, or obtuse? Fill in the sentence below to answer and explain why.

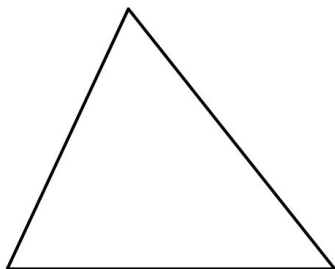

The triangle appears to be _____ because

_____.

Word Bank 1:

- 1) acute
- 2) right
- 3) obtuse

Word Bank 2:

- 1) all angles measure less than 90°
- 2) it has a right angle
- 3) one angle measures more than 90°

185. Does the triangle below appear to be acute, right, or obtuse? Fill in the sentence below to answer and explain why.

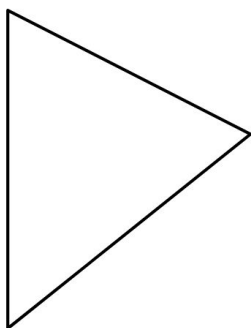

The triangle appears to be _____ because

_____.

Word Bank 1:

- 1) acute
- 2) right
- 3) obtuse

Word Bank 2:

- 1) it has 3 acute angles
- 2) one angle measures 90°
- 3) it has one obtuse angle

186. In $\triangle LMN$, $m\angle L = (3x + 4)^\circ$, $m\angle M = (2x - 14)^\circ$, and $m\angle N = (4x + 19)^\circ$. What is the value of x ?

187. In $\triangle HIJ$, \overline{HJ} is extended through point J to point K , $m\angle IJK = (7x - 12)^\circ$, $m\angle JHI = (3x - 13)^\circ$, and $m\angle HIJ = (2x + 15)^\circ$. Find $m\angle IJK$.

188. In $\triangle BCD$, $m\angle B = (4x - 11)^\circ$, $m\angle C = (5x - 19)^\circ$, and $m\angle D = (4x + 2)^\circ$. Find $m\angle C$.

189. In $\triangle JKL$, \overline{JL} is extended through point L to point M,
 $m\angle JKL = (3x + 14)^\circ$,
 $m\angle LJK = (2x + 20)^\circ$, and
 $m\angle KLM = (7x + 6)^\circ$. What is the value of x ?

190. In $\triangle ABC$, $m\angle A = (3x - 5)^\circ$,
 $m\angle B = (2x - 7)^\circ$, and $m\angle C = (5x + 2)^\circ$. Find
 $m\angle C$.

191. Select which of the shapes below is a rhombus and explain why.

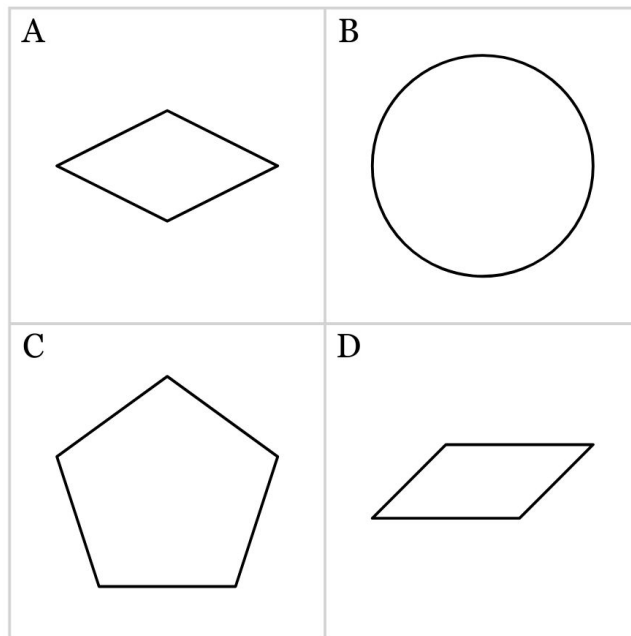

Shape ____ is a rhombus because it appears to have _____.

Word Bank:

- 1) four right angles and four equal sides
- 2) four right angles
- 3) four equal sides
- 4) two pairs of parallel sides
- 5) one pair of parallel sides

192. Select which of the shapes below is a trapezoid and explain why.

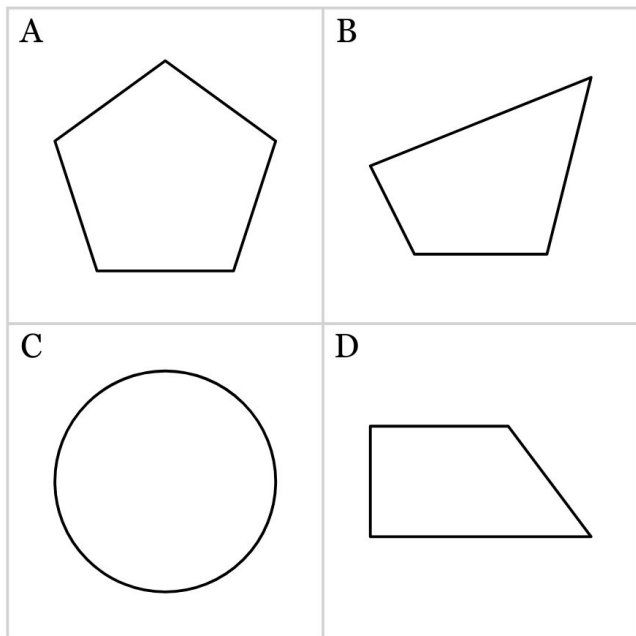

Shape ____ is a trapezoid because it appears to have _____.

Word Bank:

- 1) four right angles and four equal sides
- 2) four right angles
- 3) four equal sides
- 4) two pairs of parallel sides
- 5) one pair of parallel sides

193. Select which of the shapes below is a square and explain why.

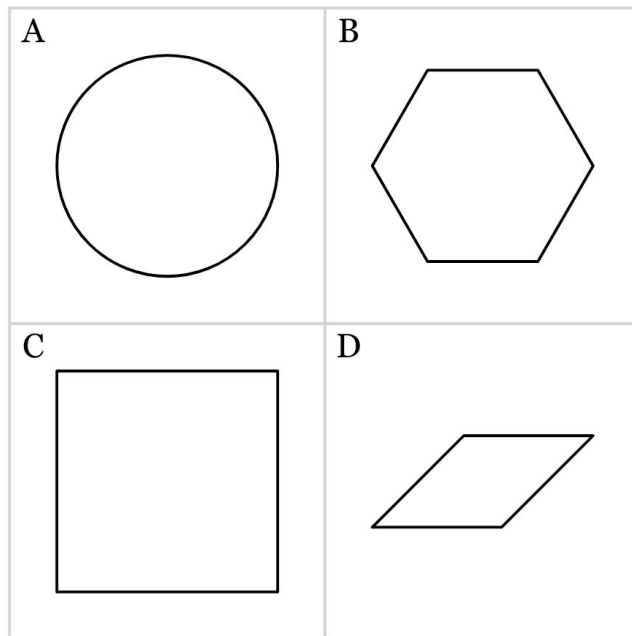

Shape ____ is a square because it appears to have _____.

Word Bank:

- 1) four right angles and four equal sides
- 2) four right angles
- 3) four equal sides
- 4) two pairs of parallel sides
- 5) one pair of parallel sides

194. Select which of the shapes below is a parallelogram and explain why.

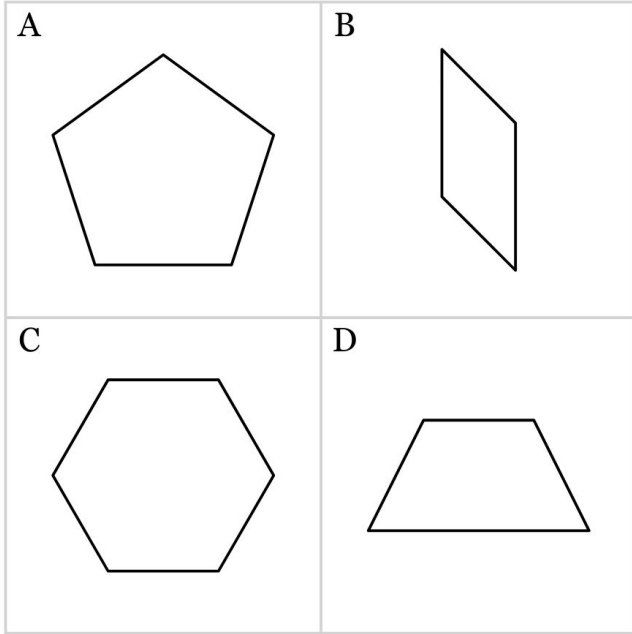

Shape ____ is a parallelogram because it appears to have _____.

Word Bank:

- 1) four right angles and four equal sides
- 2) four right angles
- 3) four equal sides
- 4) two pairs of parallel sides
- 5) one pair of parallel sides

195. Select which of the shapes below is a rectangle and explain why.

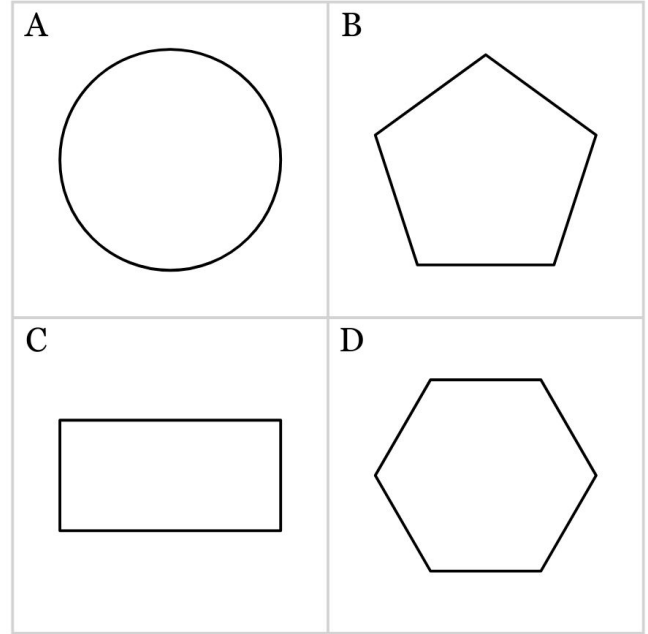

Shape ____ is a rectangle because it appears to have _____.

Word Bank:

- 1) four right angles and four equal sides
- 2) four right angles
- 3) four equal sides
- 4) two pairs of parallel sides
- 5) one pair of parallel sides

196. Choose which of the statements below is **TRUE**.

- A. A rectangle is a regular polygon.
- B. A trapezoid has four right angles.
- C. A rhombus has four equal sides.
- D. A parallelogram is a type of rectangle.

197. Choose which of the statements below is **TRUE**.

- A. A rhombus has four right angles.
- B. A square is a type of rhombus.
- C. A rectangle is a square with four right angles and four equal sides.
- D. A trapezoid has two pairs of parallel sides.

198. Choose which of the statements below is **TRUE**.

- A. A parallelogram has four right angles.
- B. A trapezoid is a four-sided shape with four right angles and equal sides.
- C. A rectangle is a type of quadrilateral.
- D. A trapezoid has four right angles and four equal sides.

199. Choose which of the statements below is **TRUE**.

- A. A rectangle is a regular polygon.
- B. A parallelogram is a type of quadrilateral.
- C. A rectangle is a square with four right angles and four equal sides.
- D. A rectangle has four right angles and four equal sides.

200. Choose which of the statements below is **TRUE**.

- A. A trapezoid is a type of quadrilateral.
- B. A parallelogram is a type of square.
- C. A rhombus is a regular quadrilateral.
- D. A rectangle is a square with four right angles and four equal sides.

201. In parallelogram BCDE if $m\angle CDE = 35^\circ$ find $m\angle EBC$.

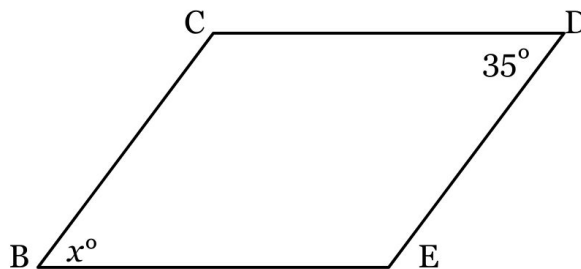

202. In parallelogram QRST if $m\angle RST = 70^\circ$ find $m\angle STQ$.

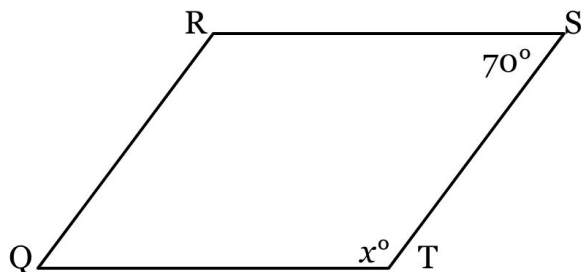

203. In parallelogram PQRS if $m\angle SPQ = 60^\circ$ find $m\angle RSP$.

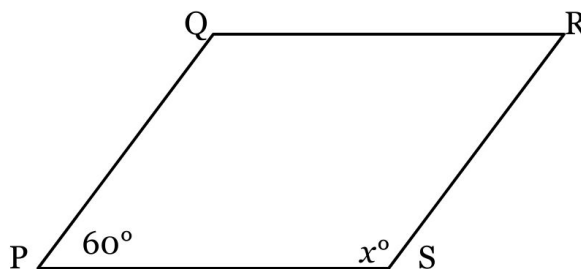

204. In parallelogram EFGH if $m\angle HEF = 40^\circ$ find $m\angle GHE$.

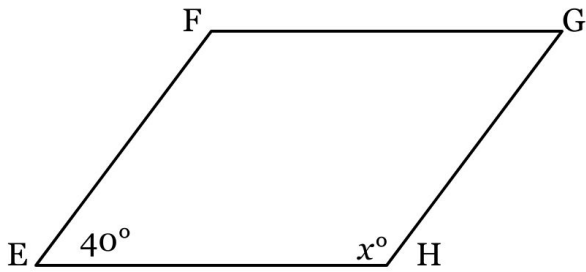

205. In parallelogram RSTU if $m\angle STU = 20^\circ$ find $m\angle RST$.

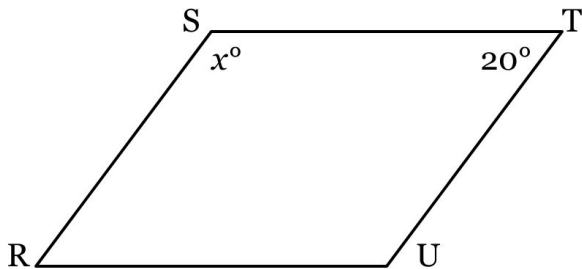

206. What is the sum of the interior angles of the polygon pictured below?

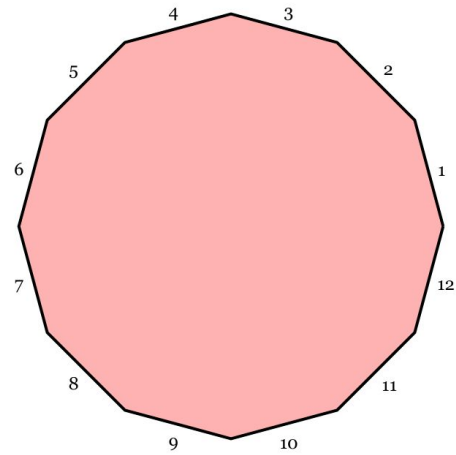

207. What is the sum of the interior angles of a heptagon?

208. Using diagonals from a common vertex, how many triangles could be formed from the polygon pictured below?

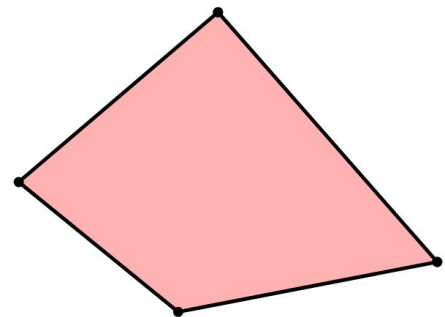

209. Using diagonals from a common vertex, how many triangles could be formed from a 21-gon?

210. What is the measure of each angle of a regular 22-gon? If necessary, round to *the nearest tenth*.

211. The area of the triangle below is $\frac{5}{36}$ square meters. What is the length of the base? Express your answer as a fraction in simplest form.

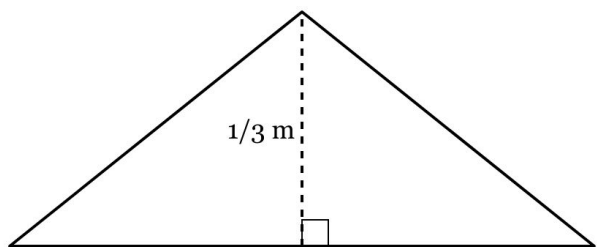

212. What is the area, in square inches, of the shape below?

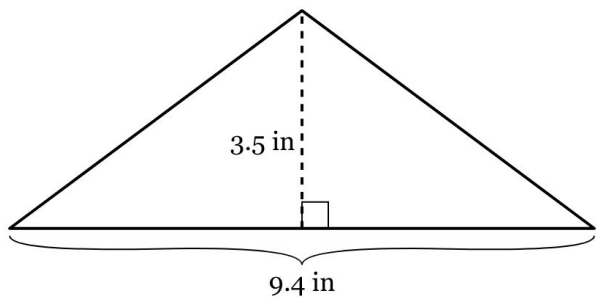

213. The area of the triangle below is $\frac{1}{20}$ square feet. What is the length of the base? Express your answer as a fraction in simplest form.

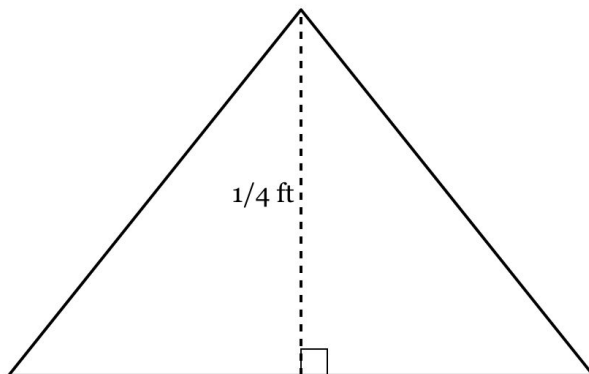

214. What is the area, in square meters, of the shape below? Express your answer as a fraction in simplest form.

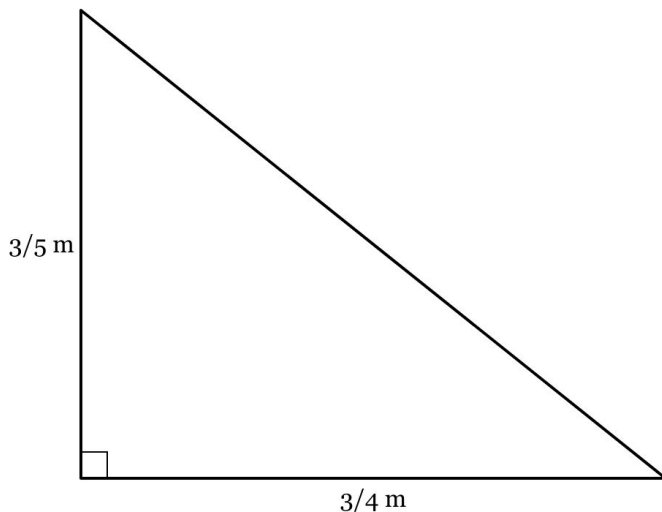

215. The area of the triangle below is 16.8 square feet. What is the length of the base?

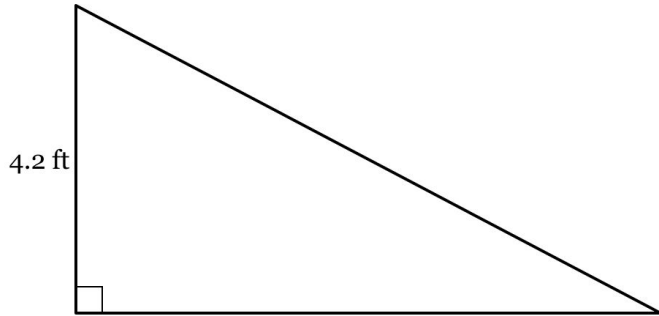

216. Given $MO=11.2$ and $NP=33.6$, find the area of rhombus $MNOP$. Round your answer to the nearest tenth if necessary.

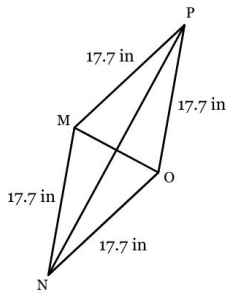

217. Find the area of trapezoid $MNOP$. Round your answer to the nearest tenth if necessary.

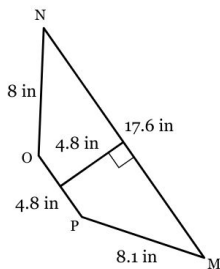

218. Find the area of rectangle $VWXY$. Round your answer to the nearest tenth if necessary.

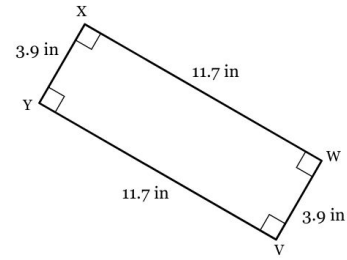

219. Find the area of parallelogram $KLMN$. Round your answer to the nearest tenth if necessary.

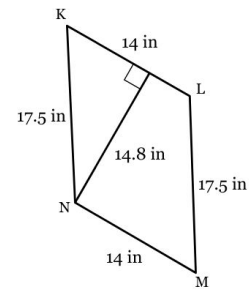

220. Given $AC=16.4$ and $BD=32.7$, find the area of rhombus $ABCD$. Round your answer to the nearest tenth if necessary.

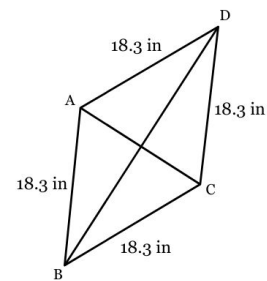

221. Find the Area of the figure below, composed of an isosceles trapezoid and one semicircle. *Rounded to the nearest tenths place*

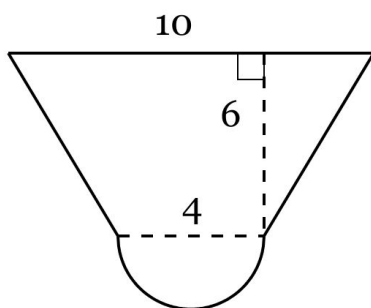

222. Find the Area of the figure below, composed of a rectangle and one semicircle, with another semicircle removed. *Rounded to the nearest tenths place.*

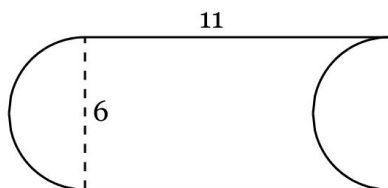

223. Find the Area of the figure below, composed of a rectangle and a semicircle. *Round to the nearest tenths place.*

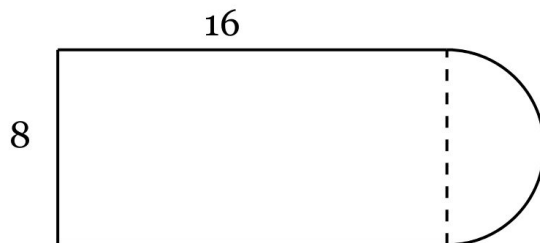

224. Find the Area of the figure below, composed of a rectangle with a semicircle removed from it. *Round to the nearest tenths place.*

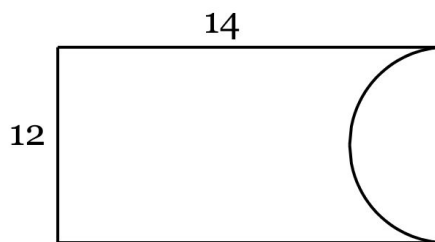

225. Find the Area of the figure below, composed of a rectangle and two semicircles. Round to the nearest tenths place.

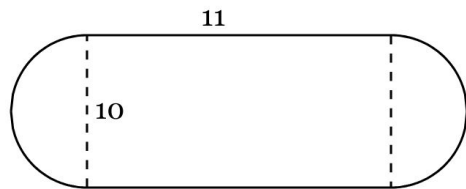

226. Lavaughn wraps a gift box in the shape of a square pyramid. The figure below shows a net for the gift box.

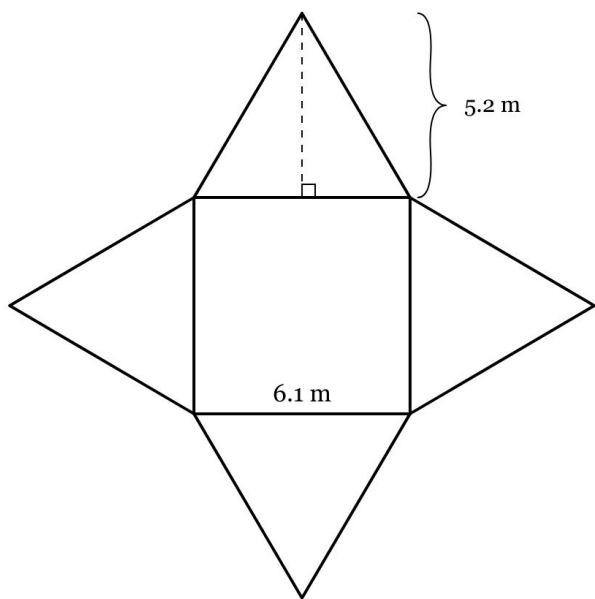

How much wrapping paper did he use, in square meters?

227. Jayden wraps a gift box in the shape of a right rectangular prism. The figure below shows a net for the gift box.

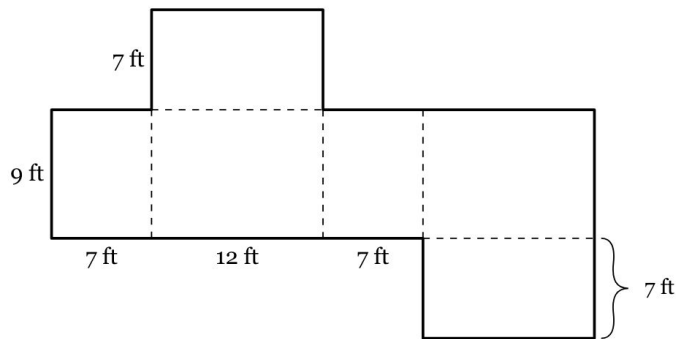

How much wrapping paper did he use, in square feet?

228. Mei Mei is decorating the outside of a box in the shape of a triangular prism. The figure below shows a net for the box.

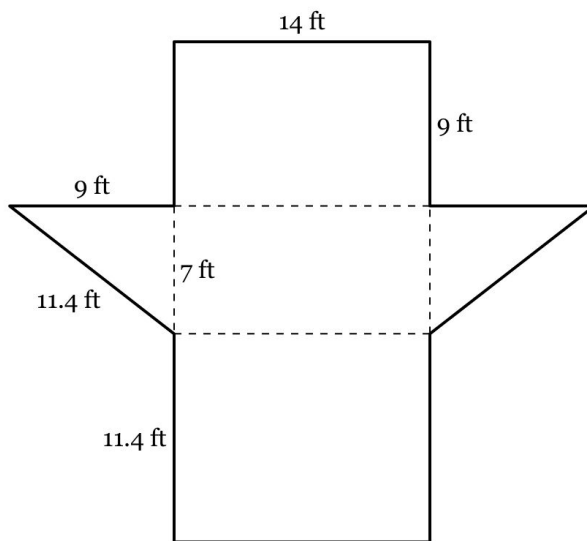

What is the surface area of the box, in square feet, that Mei Mei decorates?

229. The figure below is a net for a cube.

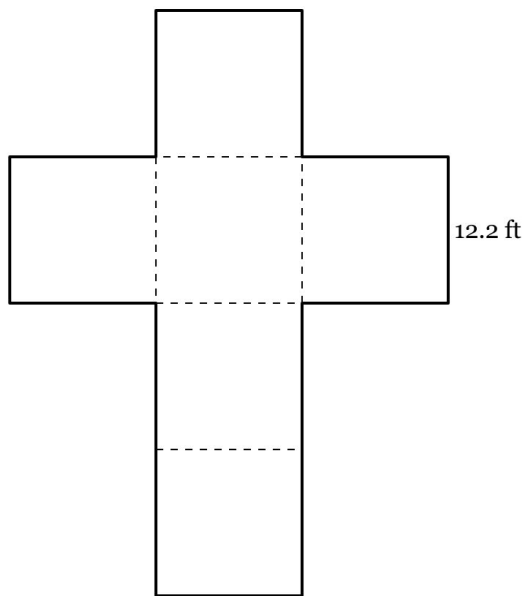

What is the surface area of the cube, in square feet?

230. Ethan built a toy box in the shape of a rectangular prism with an open top. The diagram below shows the toy box and a net of the toy box.

TOY BOX

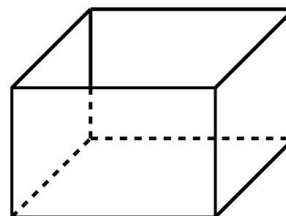

NET OF TOY BOX

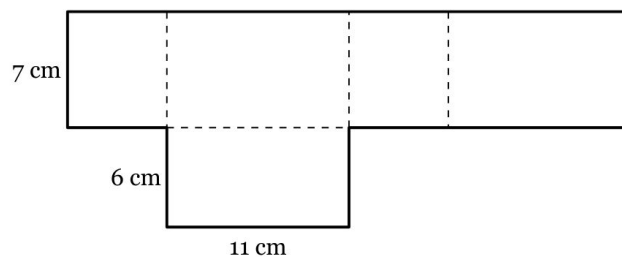

What is the surface area, in square centimeters, of the toy box?

231. Find the surface area of the rectangular prism.

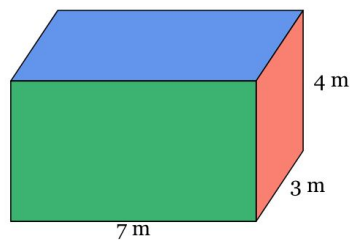

232. Find the surface area of the rectangular prism.

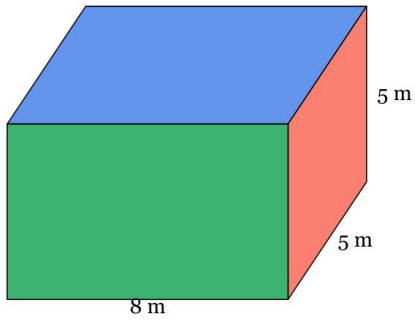

234. Find the surface area of the rectangular prism.

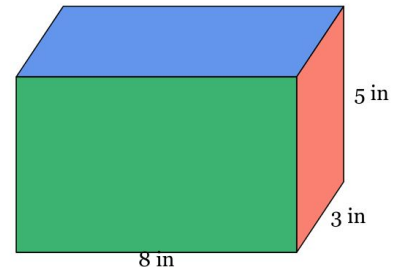

233. Find the surface area of the rectangular prism.

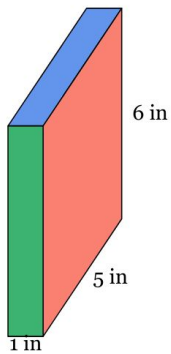

235. Find the surface area of the rectangular prism.

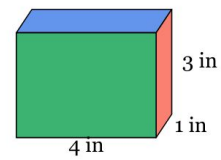

236. Find the volume in cubic meters of the right rectangular prism shown below.

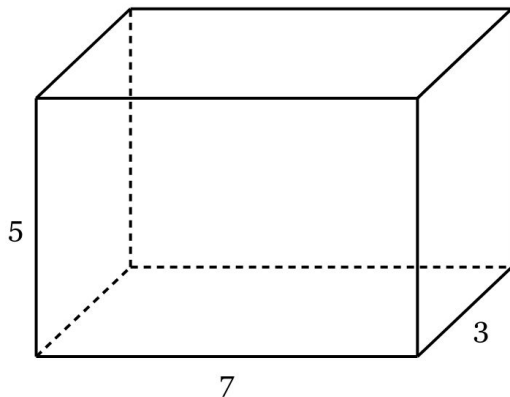

237. Find the volume in cubic feet of the right rectangular prism shown below.

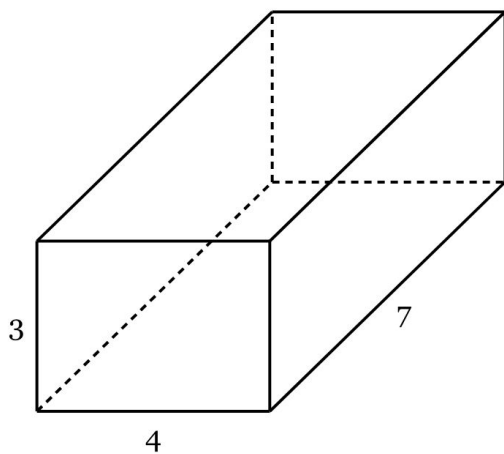

238. Find the volume in cubic centimeters of the right rectangular prism shown below.

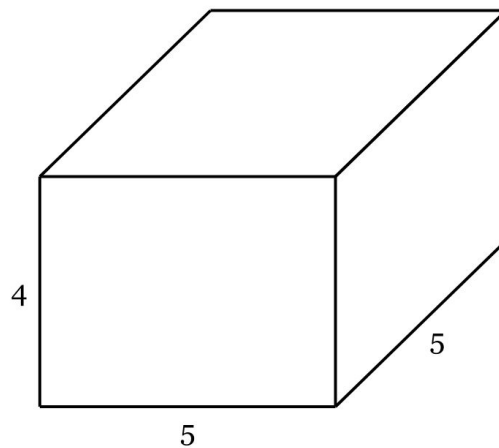

239. Find the volume in cubic meters of the right rectangular prism shown below.

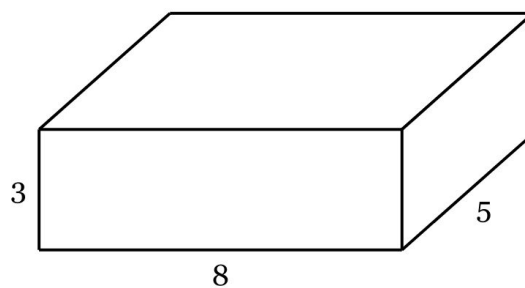

240. Find the volume in cubic meters of the right rectangular prism shown below.

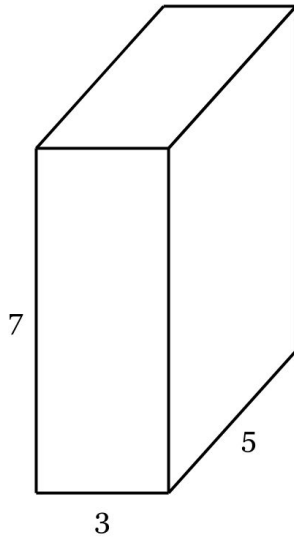

241. What is the volume, in cubic centimeters, of a cylinder with a height of 14 centimeters and a base radius of 8 centimeters, *to the nearest tenths place*?

242. What is the volume of a cylinder, in cubic meters, with a height of 18 meters and a base diameter of 14 meters? *Round to the nearest tenths place.*

243. What is the volume, in cubic inches, of a cylinder with a height of 3 inches and a base radius of 7 inches, *to the nearest tenths place*?

244. A cylinder has a base diameter of 12 meters and a height of 5 meters. What is its volume in cubic meters, *to the nearest tenths place*?

245. A cylinder has a base diameter of 16 centimeters and a height of 13 centimeters. What is its volume in cubic centimeters, *to the nearest tenths place*?

246. Plot the point $(1, 7)$ and identify the quadrant.

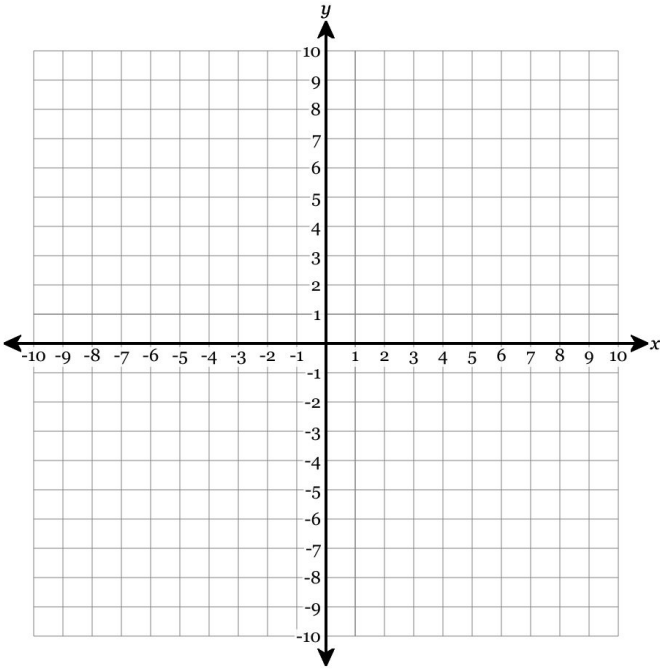

248. Plot the point $(8, -7)$ and identify the quadrant.

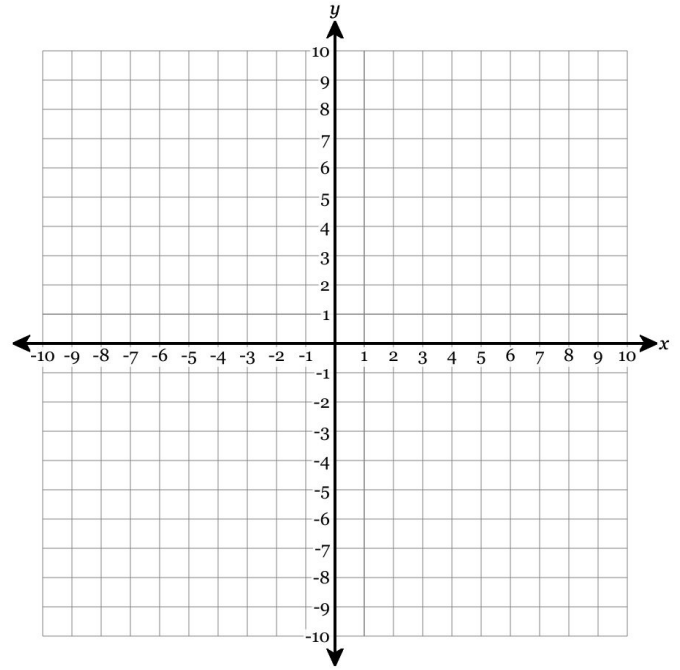

247. Plot the point $(-5, 6)$ and identify the quadrant.

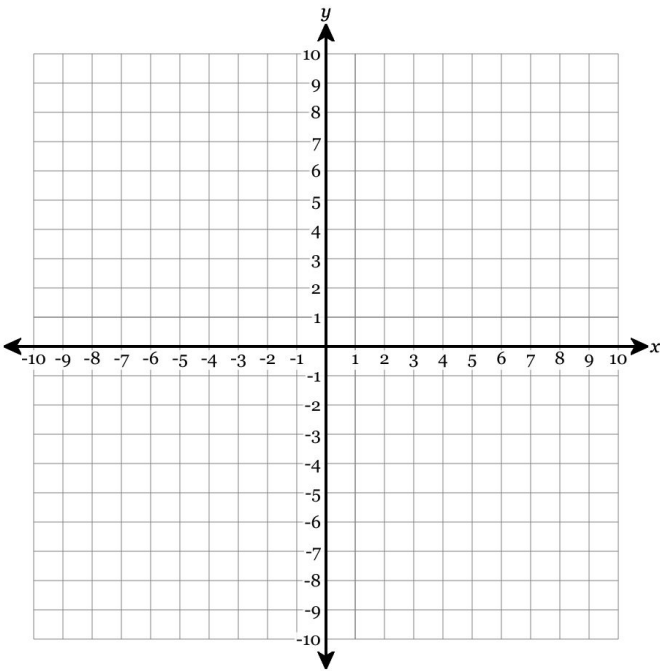

249. Plot the point $(-7, -7)$ and identify the quadrant.

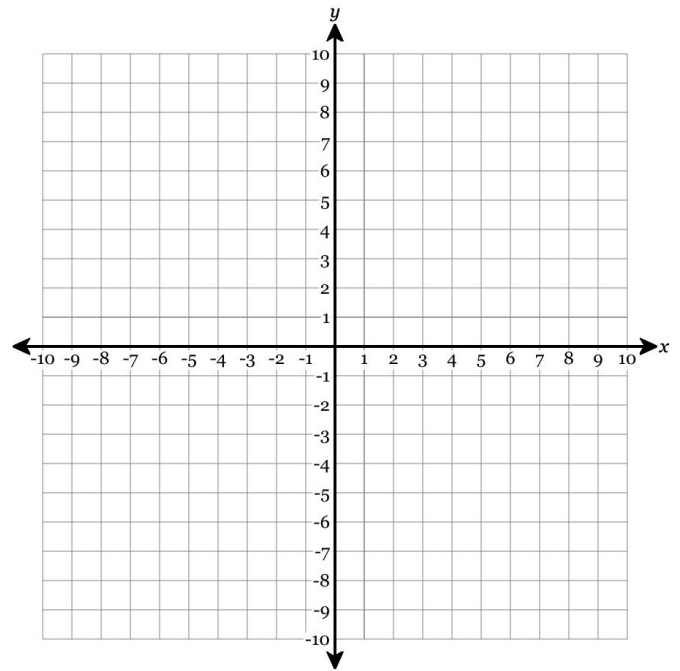

250. Plot the point $(-3, -6)$ and identify the quadrant.

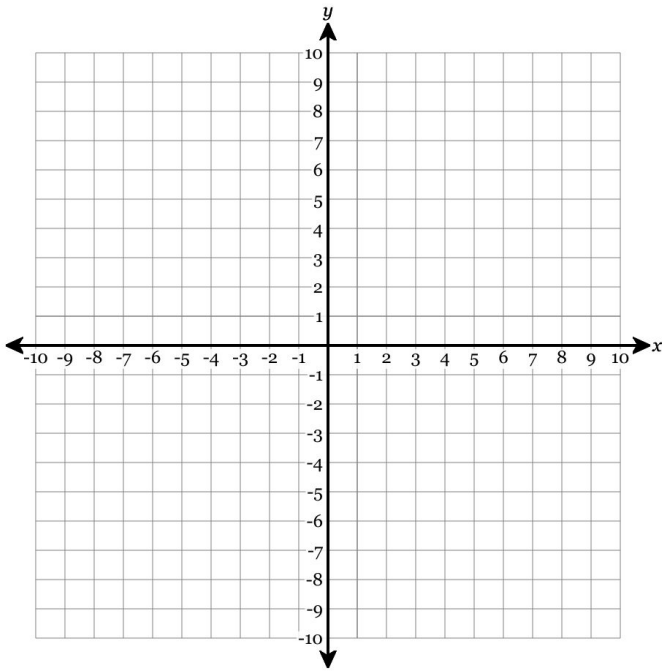

251. Graph the following features:

- Slope = $-\frac{4}{3}$
- Y-intercept = 2

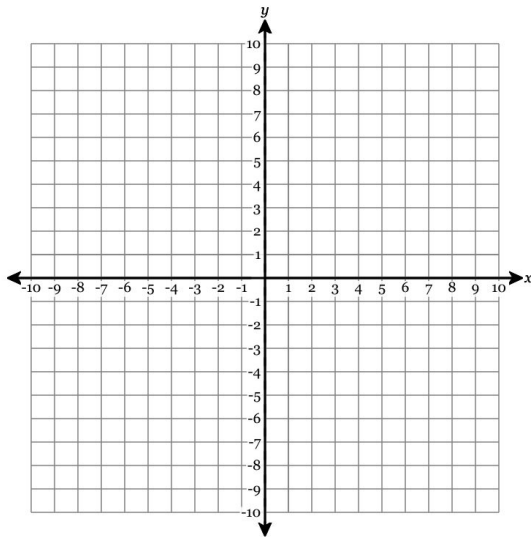

252. Graph the following features:

- Slope = $\frac{3}{4}$
- Y-intercept = 3

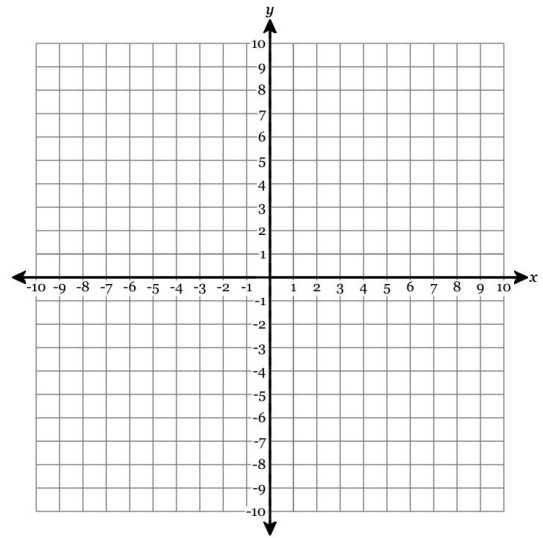

253. Graph the following features:

- Slope = -2
- Y-intercept = 5

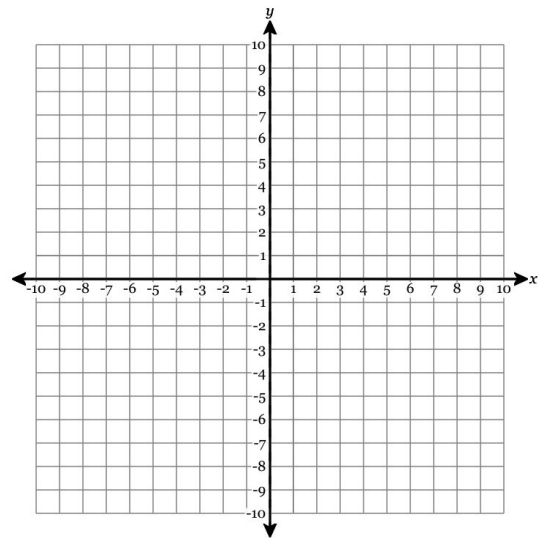

254. Graph the following features:

- Y-intercept = 1
- Slope = 2

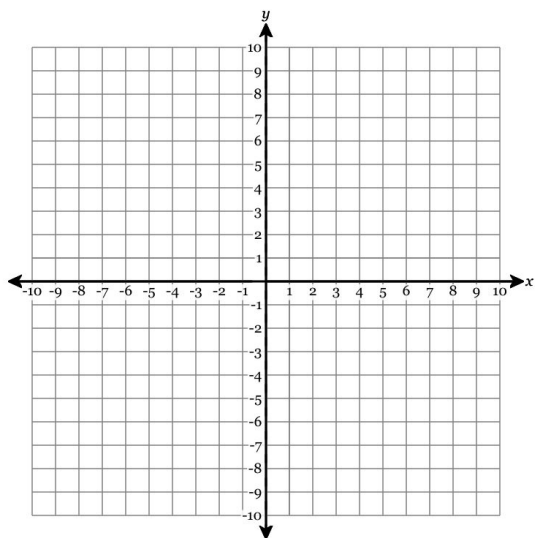

255. Graph the following features:

- Y-intercept = -2
- Slope = $-\frac{1}{6}$

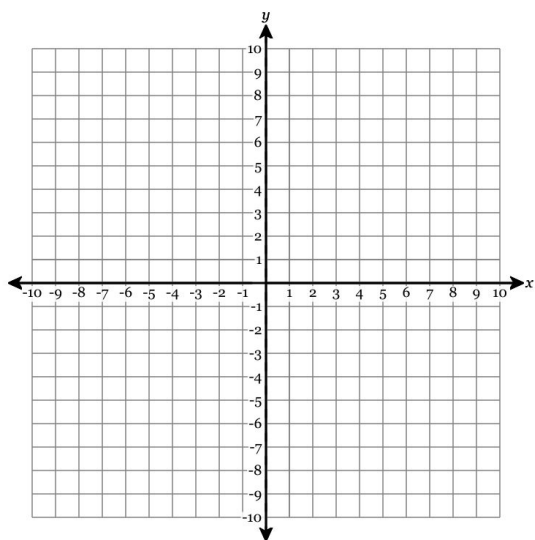

256. Graph the line with the equation $y = -\frac{2}{5}x + 1$.

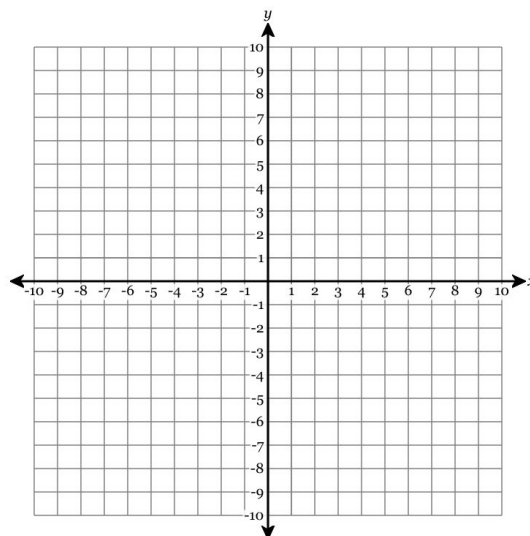

257. Graph the line with the equation $y = -\frac{1}{3}x - 2$.

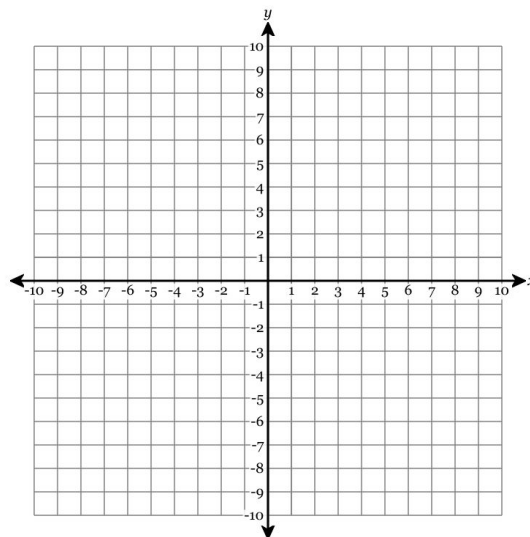

258. Graph the line with the equation $y = -3x + 3$.

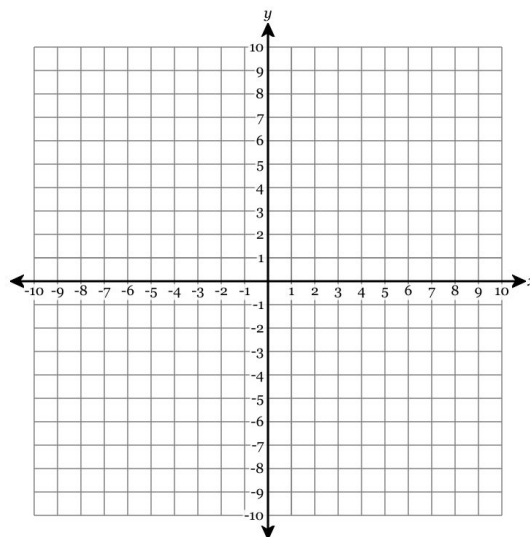

259. Graph the line with the equation $y = 2x - 2$.

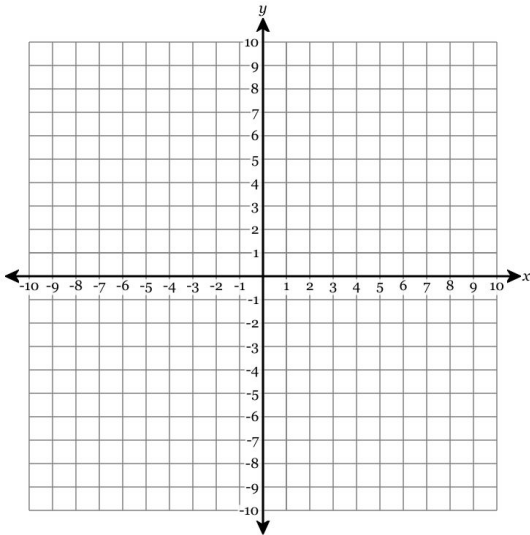

260. Graph the line with the equation $y = 2x - 1$.

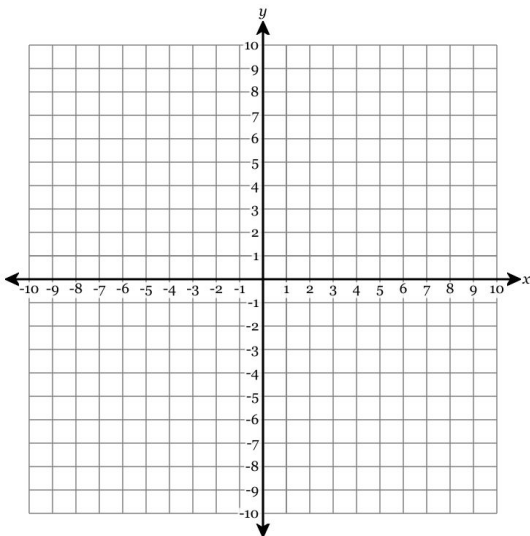

261. Draw a line representing the “rise” and a line representing the “run” of the line. State the slope of the line in simplest form.

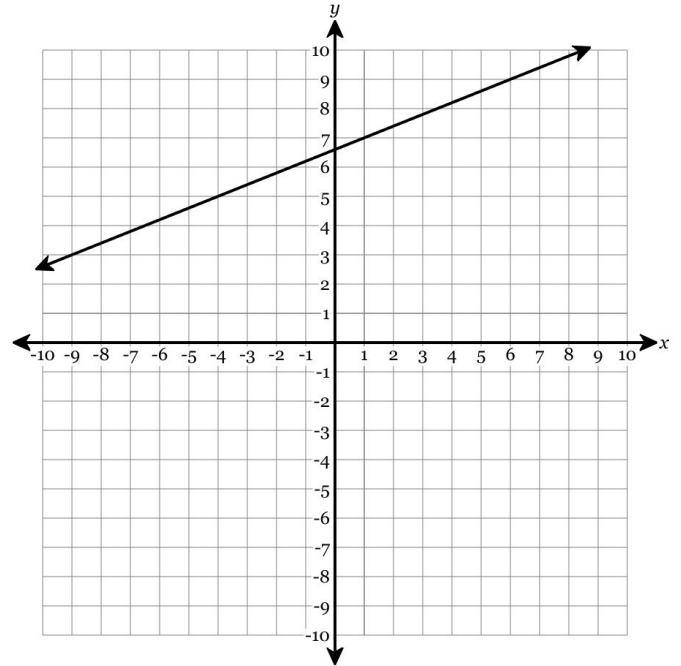

262. Draw a line representing the “rise” and a line representing the “run” of the line. State the slope of the line in simplest form.

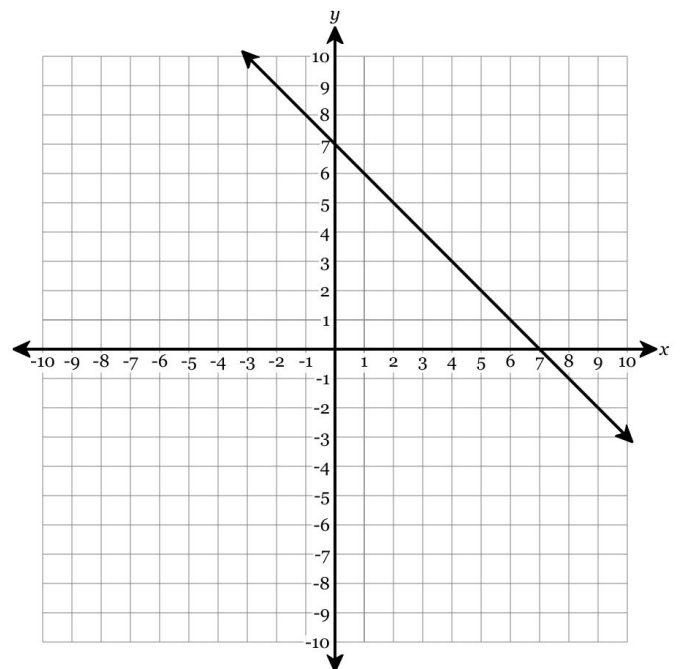

263. Draw a line representing the “rise” and a line representing the “run” of the line. State the slope of the line in simplest form.

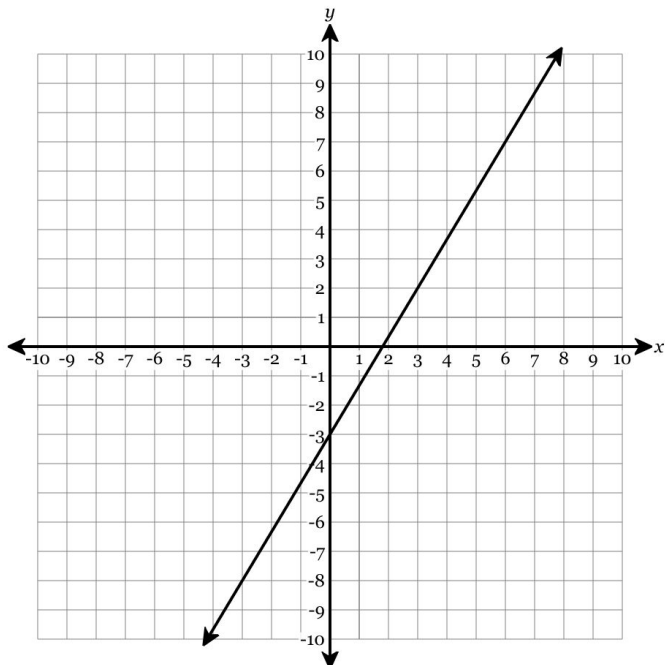

264. Draw a line representing the “rise” and a line representing the “run” of the line. State the slope of the line in simplest form.

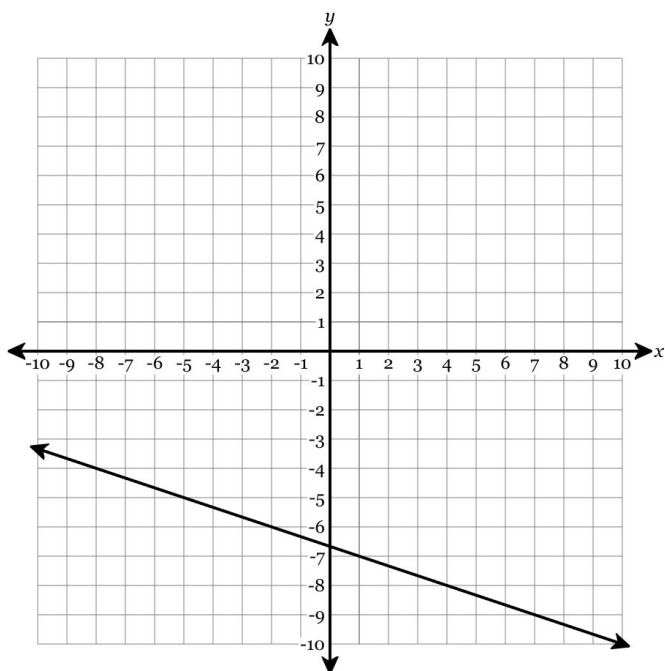

265. Draw a line representing the “rise” and a line representing the “run” of the line. State the slope of the line in simplest form.

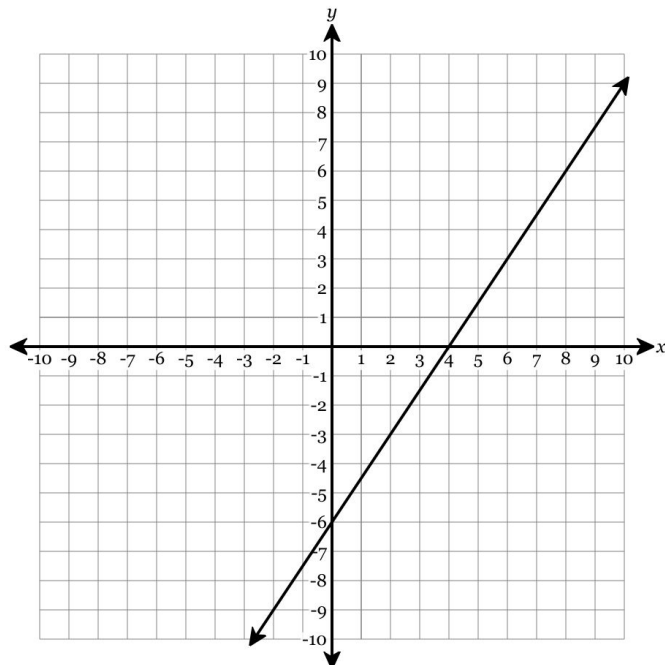

266. What is the slope of the line that passes through the points $(-5, 6)$ and $(20, 6)$? Write your answer in *simplest form*.

267. What is the slope of the line that passes through the points $(2, 5)$ and $(-13, 5)$? Write your answer in *simplest form*.

268. What is the slope of the line that passes through the points $(9, 10)$ and $(34, 10)$? Write your answer in *simplest form*.

269. What is the slope of the line that passes through the points $(2, 0)$ and $(6, 24)$? Write your answer in *simplest form*.

270. What is the slope of the line that passes through the points $(8, 1)$ and $(33, 6)$? Write your answer in *simplest form*.

271. Write the equation of the line in fully simplified slope-intercept form.

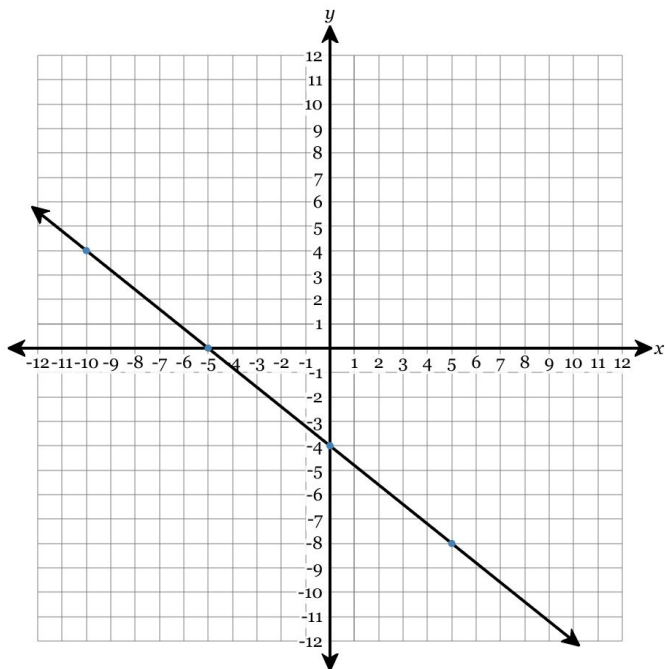

272. Write the equation of the line in fully simplified slope-intercept form.

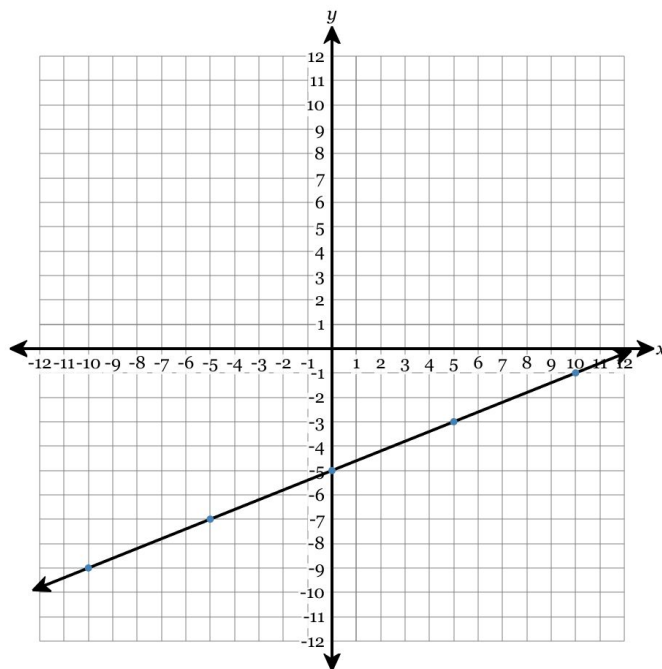

273. Write the equation of the line in fully simplified slope-intercept form.

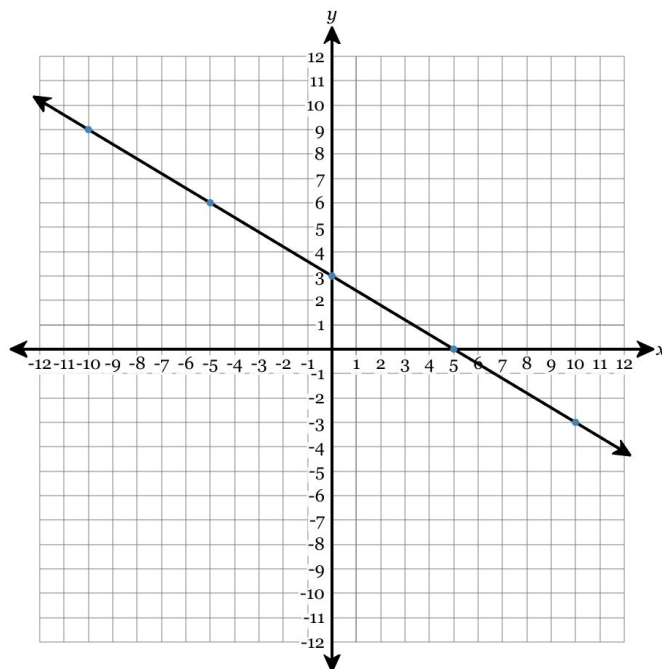

274. Write the equation of the line in fully simplified slope-intercept form.

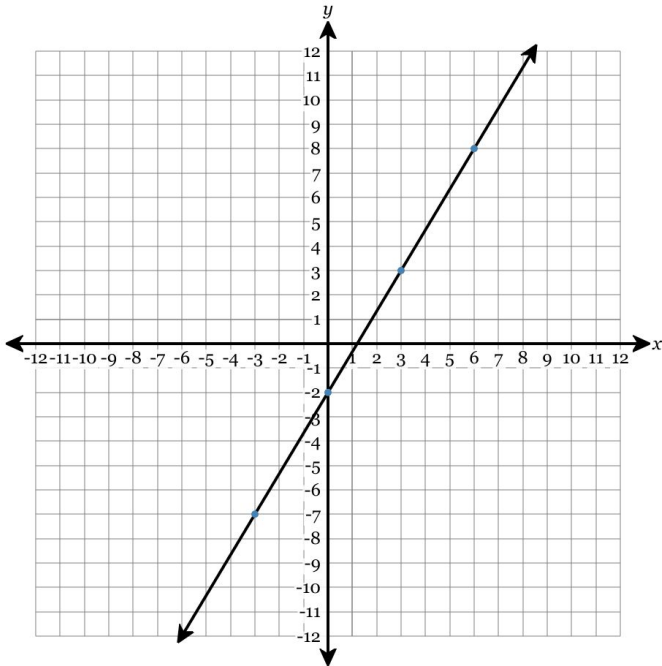

275. Write the equation of the line in fully simplified slope-intercept form.

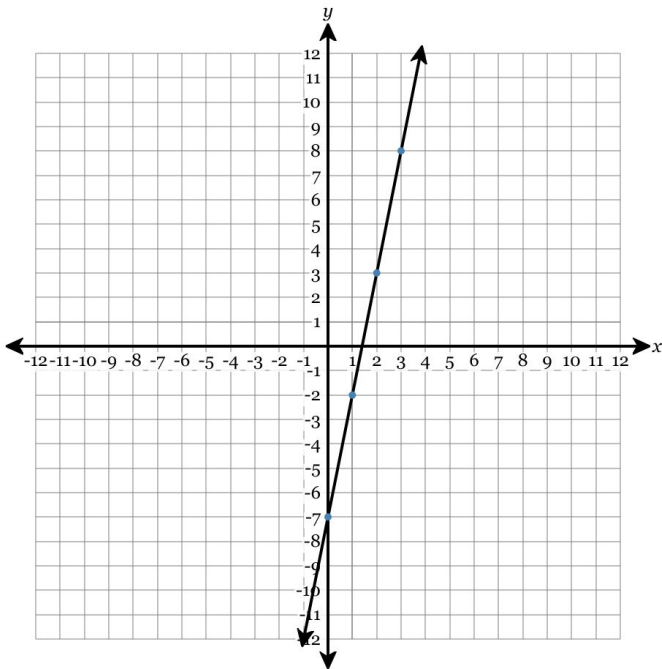

276. A spinner has 14 equally-sized sections labeled 1–14 as shown in the diagram below. What is the probability that it lands on an even section? Express your answer as a fraction.

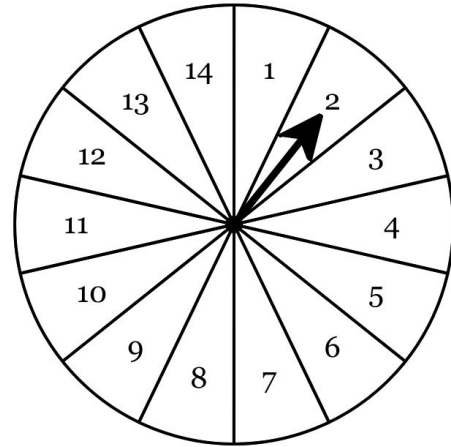

277. Suppose we pick one card at random from a standard 52-card deck. What is the probability that we pick a 5? Express your answer as a fraction.

278. Suppose we roll a fair 10-sided die with sides numbered 1–10. What is the probability that it lands showing a number greater than 8? Express your answer as a fraction.

279. A bag contains 6 orange, 7 red, 1 yellow, and 1 blue fruit chew. Suppose that we randomly choose a fruit chew. What is the probability that we pick a yellow fruit chew? Express your answer as a fraction.

280. Suppose we pick one card at random from a standard 52-card deck. What is the probability that we pick a 6 of hearts? Express your answer as a fraction.

281. A fair 6-sided die has sides numbered from 1 to 6. Sadie rolled the die 40 times. She rolled a two 5 times. Find both the experimental and theoretical probability the die lands showing a 2.

Experimental Probability =

Theoretical Probability =

282. A spinner has 6 equally-sized sections labeled R, S, T, U, V, W. Suav spun the arrow 15 times. It landed on the letter T a total of 3 times.

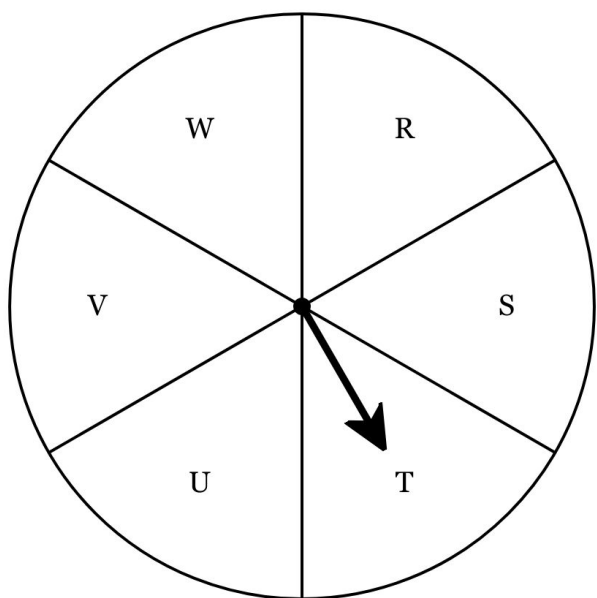

Find both the experimental and theoretical probability of landing on the letter T.

Experimental Probability =

Theoretical Probability =

283. A spinner has 8 equally-sized sections labeled M, N, N, N, N, O, P. Jevonte spun the arrow 50 times. It landed on the letter N a total of 29 times.

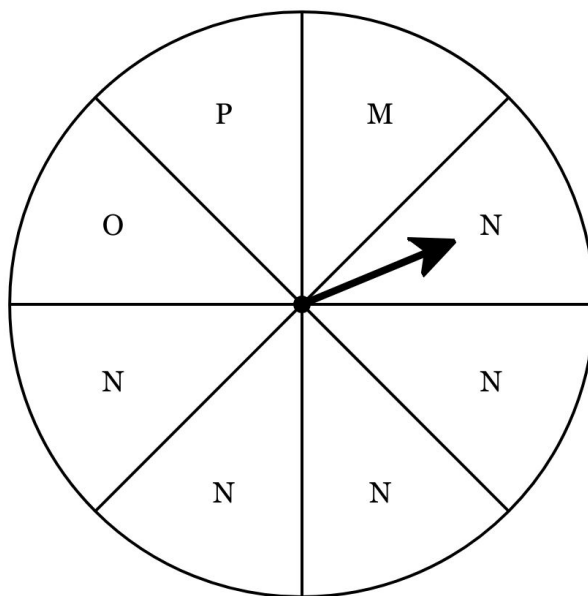

Find both the experimental and theoretical probability of landing on the letter N.

Experimental Probability =

Theoretical Probability =

284. A spinner has 6 equally-sized sections labeled S, T, T, T, U, V. Zoey spun the arrow 50 times. It landed on the letter U a total of 7 times.

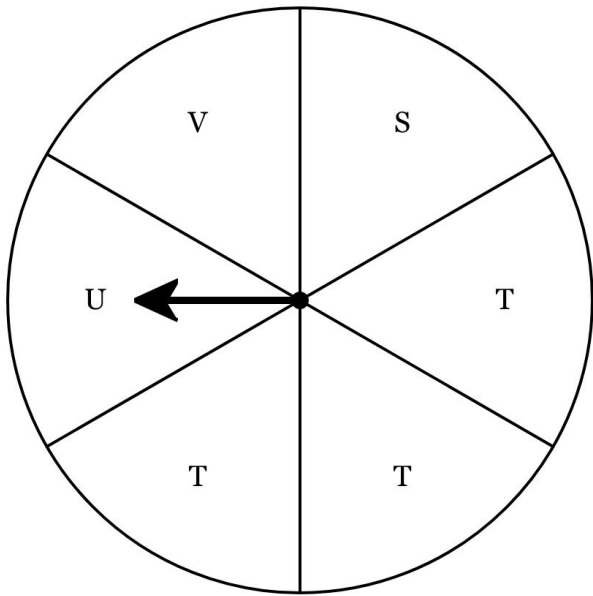

Find both the experimental and theoretical probability of landing on the letter U.

Experimental Probability =

Theoretical Probability =

285. A fair 12-sided die has sides numbered from 1 to 12. Xochitl rolled the die 20 times. She rolled a ten 1 time. Find both the experimental and theoretical probability the die lands showing a 10.

Experimental Probability =

Theoretical Probability =

286. Complete the frequency table for the following set of data.

10, 7, 11, 1, 1, 11, 0, 0, 10, 3, 8, 1, 10,
10, 8

Interval	Tally	Frequency
0 – 1		
2 – 3		
4 – 5		
6 – 7		
8 – 9		
10 – 11		

287. Complete the frequency table for the following set of data.

20, 42, 36, 5, 53, 43, 18, 4, 48, 23, 20,
8, 55, 16, 23, 36, 53, 1, 24, 2, 30, 48,
59, 22, 55, 20, 45, 44, 29, 0, 1

Interval	Tally	Frequency
0 – 9		
10 – 19		
20 – 29		
30 – 39		
40 – 49		
50 – 59		

288. Complete the frequency table for the following set of data.

16, 25, 16, 25, 15, 3, 21, 15, 28, 26, 24,
27, 27, 22, 1, 1, 27, 9, 7, 25, 8

Interval	Tally	Frequency
0 – 4		
5 – 9		
10 – 14		
15 – 19		
20 – 24		
25 – 29		

290. Complete the frequency table for the following set of data.

36, 2, 34, 12, 7, 31, 31, 21, 37, 3, 29,
39, 33, 3, 5

Interval	Tally	Frequency
0 – 9		
10 – 19		
20 – 29		
30 – 39		

289. Complete the frequency table for the following set of data.

49, 47, 9, 29, 29, 46, 13, 43, 1, 10, 49,
29, 13, 21, 44, 44, 9, 43, 19, 18, 37, 18

Interval	Tally	Frequency
0 – 9		
10 – 19		
20 – 29		
30 – 39		
40 – 49		

291. Certain students recorded how far in feet they could throw a frisbee, as shown in the data below.

20, 24, 26, 29, 30, 31, 32, 32, 34, 37, 41, 47

Match the data to the correct stem and leaf plot below.

Key: $2 \mid 0 = 20$ feet

A.
$$\begin{array}{l|l} 2 & 1\ 6\ 7\ 9 \\ 3 & 0\ 1\ 2\ 4\ 4\ 7 \\ 4 & 0\ 2 \end{array}$$

B.
$$\begin{array}{l|l} 2 & 4\ 6\ 9 \\ 3 & 1\ 2\ 2\ 4\ 7 \\ 4 & 1\ 7 \end{array}$$

C.
$$\begin{array}{l|l} 2 & 0\ 4\ 6\ 9 \\ 3 & 0\ 1\ 2\ 2\ 4\ 7 \\ 4 & 1\ 7 \end{array}$$

D.
$$\begin{array}{l|l} 2 & 4 \\ 3 & 6 \\ 4 & 2 \end{array}$$

292. Students in the school band recorded the number of minutes they spent practicing their instruments this week, as shown in the data below.

30, 30, 31, 32, 32, 36, 41, 49, 53, 53, 54, 59

Match the data to the correct stem and leaf plot below.

Key: $3 \mid 0 = 30$ minutes

A.
$$\begin{array}{l|l} 3 & 6 \\ 4 & 2 \\ 5 & 4 \end{array}$$

B.
$$\begin{array}{l|l} 3 & 0\ 0\ 1\ 2\ 2\ 6 \\ 4 & 1\ 9 \\ 5 & 3\ 3\ 4\ 9 \end{array}$$

C.
$$\begin{array}{l|l} 3 & 1\ 2\ 2\ 6 \\ 4 & 1\ 9 \\ 5 & 3\ 3\ 4\ 9 \end{array}$$

D.
$$\begin{array}{l|l} 3 & 0\ 0\ 1\ 1\ 3\ 9 \\ 4 & 2\ 4 \\ 5 & 2\ 3\ 6\ 9 \end{array}$$

293. Certain students participated in the long jump at field day. The length of their jumps, in inches, is shown in the data below.

60, 62, 63, 66, 67, 68, 73, 79, 82, 84, 87, 89

Match the data to the correct stem and leaf plot below.

Key: $6 | 0 = 60$ inches

A.
$$\begin{array}{r|l} 6 & 6 \\ 7 & 2 \\ 8 & 4 \end{array}$$

B.
$$\begin{array}{r|l} 6 & 2\ 3\ 6\ 7\ 8 \\ 7 & 3\ 9 \\ 8 & 2\ 4\ 7\ 9 \end{array}$$

C.
$$\begin{array}{r|l} 6 & 0\ 2\ 4\ 6\ 9\ 9 \\ 7 & 3\ 7 \\ 8 & 2\ 3\ 7\ 8 \end{array}$$

D.
$$\begin{array}{r|l} 6 & 0\ 2\ 3\ 6\ 7\ 8 \\ 7 & 3\ 9 \\ 8 & 2\ 4\ 7\ 9 \end{array}$$

294. The number of minutes it takes different students to get to school is shown in the data below.

10, 12, 13, 14, 17, 22, 25, 26, 28, 29, 36, 39

Match the data to the correct stem and leaf plot below.

Key: $1 | 0 = 10$ minutes

A.
$$\begin{array}{r|l} 1 & 0\ 2\ 3\ 4\ 7 \\ 2 & 2\ 5\ 6\ 8\ 9 \\ 3 & 6\ 9 \end{array}$$

B.
$$\begin{array}{r|l} 1 & 5 \\ 2 & 5 \\ 3 & 2 \end{array}$$

C.
$$\begin{array}{r|l} 1 & 2\ 4\ 5\ 6\ 7 \\ 2 & 2\ 3\ 6\ 8\ 9 \\ 3 & 0\ 9 \end{array}$$

D.
$$\begin{array}{r|l} 1 & 2\ 3\ 4\ 7 \\ 2 & 2\ 5\ 6\ 8\ 9 \\ 3 & 6\ 9 \end{array}$$

295. The number of minutes it takes different students to get to school is shown in the data below.

10, 14, 14, 15, 18, 22, 23, 24, 25, 35, 37, 38

Match the data to the correct stem and leaf plot below.

Key: $1 | 0 = 10$ minutes

A.
$$\begin{array}{l|l} 1 & 4\ 4\ 5\ 8 \\ 2 & 2\ 3\ 4\ 5 \\ 3 & 5\ 7\ 8 \end{array}$$

B.
$$\begin{array}{l|l} 1 & 0\ 4\ 4\ 5\ 8 \\ 2 & 2\ 3\ 4\ 5 \\ 3 & 5\ 7\ 8 \end{array}$$

C.
$$\begin{array}{l|l} 1 & 0\ 3\ 4\ 5\ 7 \\ 2 & 2\ 4\ 5\ 8 \\ 3 & 4\ 5\ 8 \end{array}$$

D.
$$\begin{array}{l|l} 1 & 5 \\ 2 & 4 \\ 3 & 3 \end{array}$$

296. A coach put all of their players' 40-yard dash times in the stem-and-leaf plot below.

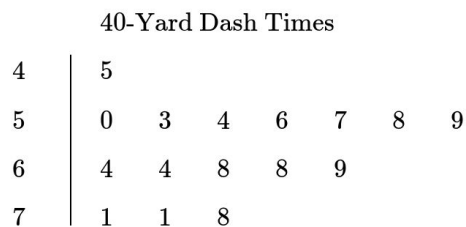

Key: $7 | 1 = 7.1$ seconds

What was the fastest (shortest) time?

297. The stem-and-leaf plot below represents the number of students in each math class at a school.

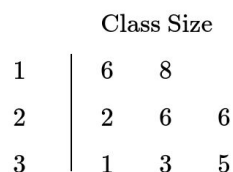

Key: $1 | 6 = 16$ students

What is the most common class size?

298. A teacher put all of their student's quiz scores in the stem-and-leaf plot below.

Quiz Scores	
6	0 1 4 4 8
7	0 4 5 5 6 9
8	2 7 9
9	0 0 2 3 5 5 6 9 9
10	0

Key: $6 \mid 0 = 60$ points

What was the median quiz score?

299. A coach put all of their players' 40-yard dash times in the stem-and-leaf plot below.

40-Yard Dash Times	
4	3 8
5	2 3 3 3 3 3 6
6	1 3 3 4 7 7 9
7	2 4

Key: $4 \mid 3 = 4.3$ seconds

What was the range of the times?

300. Each member of a bowling team bowled a game. Their scores are shown in the stem-and-leaf plot below.

Bowling Scores	
15	2 4
16	0 2 8
17	3 6
18	
19	0 1 4 6

Key: $15 \mid 2 = 152$ points

How many members were there?

301. Find the median and mean of the data set below:

48, 37, 29, 40

302. Find the median and mean of the data set below:

9, 5, 21, 49, 46, 44, 36

303. Find the median and mean of the data set below:

15, 5, 38, 35, 33

304. Find the median and mean of the data set below:

13, 1, 10, 48, 7

305. Find the median and mean of the data set below:

12, 43, 21, 25, 9, 18, 19